

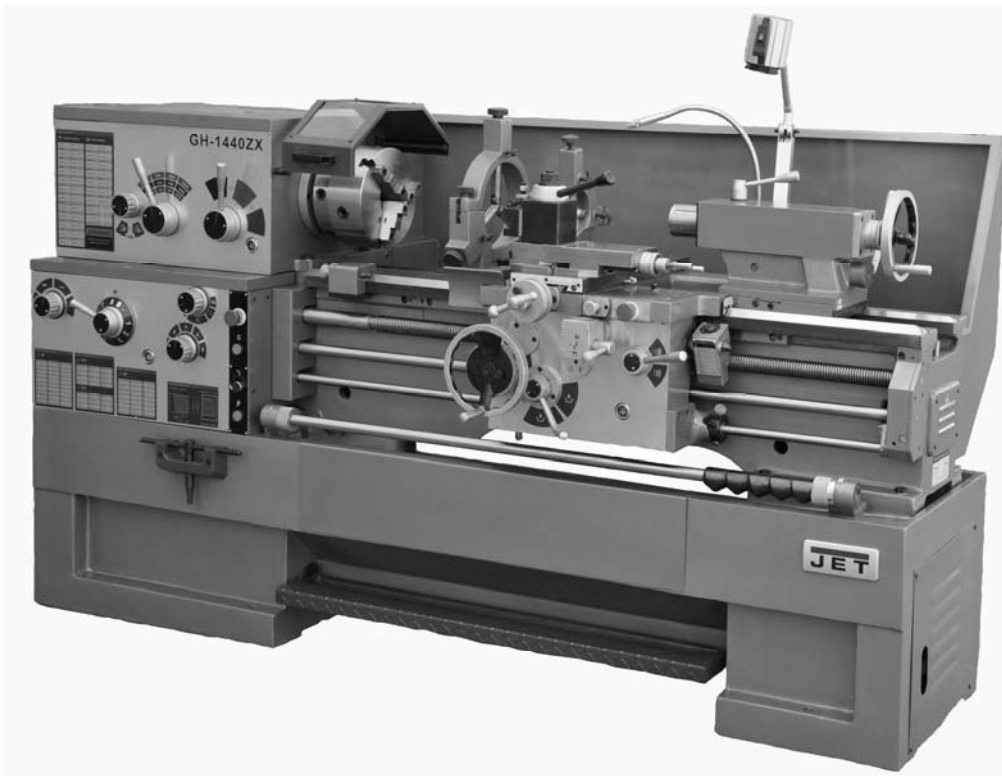

Model No.:	Stock No.:
Serial No.:	
Purchased From:	
Date Purchased:	Date Installed:

# Parts List and Electrical Diagrams ZX-Series Large Bore Lathes

Models GH-1440ZX  
GH-1640ZX/1660ZX  
GH-1860ZX/1880ZX  
GH-2280ZX



*Model GH-1440ZX shown*

**\* For ZX-Series Lathes Operating Instructions, see document M-321910**

**JET**

427 New Sanford Road  
LaVergne, Tennessee 37086  
Ph.: 800-274-6848  
www.jettools.com

**Part No. M-321910-1**  
Revision I 04/2016  
Copyright © 2016 JET

## Table of Contents

Table of Contents .....	2
Stand Assembly .....	3-5
Brake Assembly .....	6-7
Bed Assembly .....	8-10
Headstock Assembly I.....	11-14
Headstock Assembly II.....	15-17
Headstock Assembly III.....	18-19
Headstock Assembly IV .....	20-21
Change Gear Box Assembly I.....	22-23
Change Gear Box Assembly II.....	24-25
Quick Change Gear Box I .....	26-28
Quick Change Gear Box II .....	29-30
Quick Change Gear Box III .....	31-32
Apron Assembly I .....	33-35
Apron Assembly II .....	36-38
Apron Assembly III .....	39-40
Carriage Assembly.....	41-43
Micro Carriage Stop Assembly .....	44
Carriage Stop Assembly .....	45-46
Quick Change Tool Post .....	47-48
Tailstock Assembly I .....	49-50
Tailstock Assembly II .....	51-52
Steady Rest Assembly .....	53-54
Follow Rest Assembly.....	55-56
Coolant And Work Light Assembly .....	57-58
Other Parts .....	59
Electrical Cabinet .....	60-61
Wiring Diagram .....	62
Rotary Switch Diagram .....	63
Safety Guard Cover .....	64
Carriage lubrication .....	65



## Stand Assembly

Index No.	Part No.	Description	Size	Qty.
1	ZX-01101A	Pulley		1
	GH2280ZX-01101	Pulley (for 2280ZX)		1
2	ZX-S2	Cylindrical End Set Screw	M8x16	1
3	ZX-01734-G	Cover		1
	ML-2080-01701-G	Cover (for 2280ZX)		1
4	ZX-S4	Cross Head Screw	M6x14	4
5	ZX-S2	Cylindrical End Set Screw	M8x16	1
6	ZX-01701	Pedal Rod Support		1
	ML-2080-01703	Pedal Rod Support (for 2280ZX)		1
7	ZX-01715	Lining		6
8	TS-1540231	Hex Nut	M24-2	6
9	ZX-01712	Hex Cap Bolt		3
9A	ZX-01713	Hex Cap Bolt		3
10	ZX-01102A	Bed Stand (for 40" models, serial # 010611ZX349 and lower)		1
	ZX-01102AN	New Bed Stand (for 40" models, serial # 010618ZX350 and lower)		1
	ZX-01102AN-G	Bed Stand (for 40" models)		1
	ZX-01102B	Bed Stand (for 60" models, serial # 010611ZX349 and lower)		1
	ZX-01102BN	New Bed Stand (for 60" models, serial # 010618ZX350 and lower)		1
	ZX-01102BN-G	Bed Stand (for 60" models)		1
	ZX-01102C	Bed Stand (for 1880ZX, serial # 010611ZX349 and lower)		1
	ZX-01102CN	New Bed Stand (for 1880ZX, serial # 010618ZX350 and lower)		1
	ZX-01102CN-G	Bed Stand (for 1880ZX)		1
	GH2280ZX-01102-G	Bed Stand (for 2280ZX)		1
11	ZX-01703	Fixed Support		1
12	TS-150341	Socket Head Cap Screw	M6x14	4
13	ZX-S13	Taper Pin	5x20	2
14	ZX-01705	Water Leaking Chip Guard		1
15	ZX-S15A	Cross Head Screw	M5x20	4
16	TS-1540121	Hex Nut	M20	9
17	ZX-01702	Bolt		3
	ML-2080-01704	Bolt (for 2280ZX)		3
18	TS-1550111	Flat Washer	M20	6
19	ZX-01122A	Motor Mounting Plate (for 14" models)		1
	ZX-01122B	Motor Mounting Plate (for 16"/18" models)		1
	ML-2080-01122	Motor Mounting Plate (for 22" model))		1
20	ZX-01726-G	Cover		1
	GH2280ZX-01701-G	Cover		1
21	ZX-S4	Cross Head Screw	M6x14	4
22	ZX-S22	Key	10x8x70	1
23	ZX-S23BC	Main Motor (for 22" model)	10 HP, 6P, 3Ph	1
	ZX-S23A	Main Motor (for 14" models)	7.5HP, 4P, 3Ph	1
	ZX-S23B	Main Motor (for 16"/18" models)	7.5HP, 6P, 3Ph	1
24	ZX-017609A	Wire Conduit (for 1440/1640/1840ZX)		1
	ZX-017609B	Wire Conduit (for 1460/1660/1860ZX)		1
	ZX-017609C	Wire Conduit (for 1880/2280ZX)		1
26	ZX-01706	Locking Plate		1
28	ZX-S15	Cross Head Screw	M4x6	1
29	ZX-01711-G	Water Reception Plate		1
30	ZX-S4	Cross Head Screw	M6x14	2
31	ZX-01510	Coolant Tank		1
32	ZX-01714-G	Cover		1
	ML-2080-01702-G	Cover (for 2280ZX)		1
33	ZX-S4	Cross Head Screw	M6x14	6
34	ZX-S34	Nut	M3	4
35	ZX-S35	Coolant Indicator		1
36	ZX-S36	Cross Head Screw	M3x20	4

Index No.	Part No.	Description	Size	Qty.
37	TS-1540072	Hex Nut	M10	4
38	TS-1550071	Flat Washer	M10	4
39	TS-1491041	Hex Cap Bolt	M10x30	4
80	ZX-01716A-G	Stand Front Cover (for 1440/1640/1840ZX)		1
	ZX-01716B-G	Stand Front Cover (for 1460/1660/1860ZX)		1
	ZX-01716C-G	Stand Front Cover (for 1880/2280ZX)		1
81	ZX-01501	Gasket		1
82	ZX-S82	Hex Nut	M5	2
83	ZX-01740	Left Tray		1
84	ZX-01741	Right Tray		1
85	ZX-01511	Gasket		2
86	ZX-S86	Cross Head Screw	M5x16	6
87	ZX-01512	Gasket		1
88	ZX-05753-G	Extending Plate		1
89	ZX-01703A	Fixed Support (serial # 070916ZX1738 and higher)		1
90	1440R09302A	Chuck Key Holder (serial # 160410ZX3032 and higher)		1
91	GB70- M8x50	Hex Socket Cap Screw (serial # 160410ZX3032 and higher)	M8x50	2
92	JET-165	JET LOGO		1
93	JX21004-G	Terminal Board (not shown)		1
94	18301-G	Junction Box (not shown)		1
95	D97-4-G	Plastic Fitting (not shown)		1

# Brake Assembly

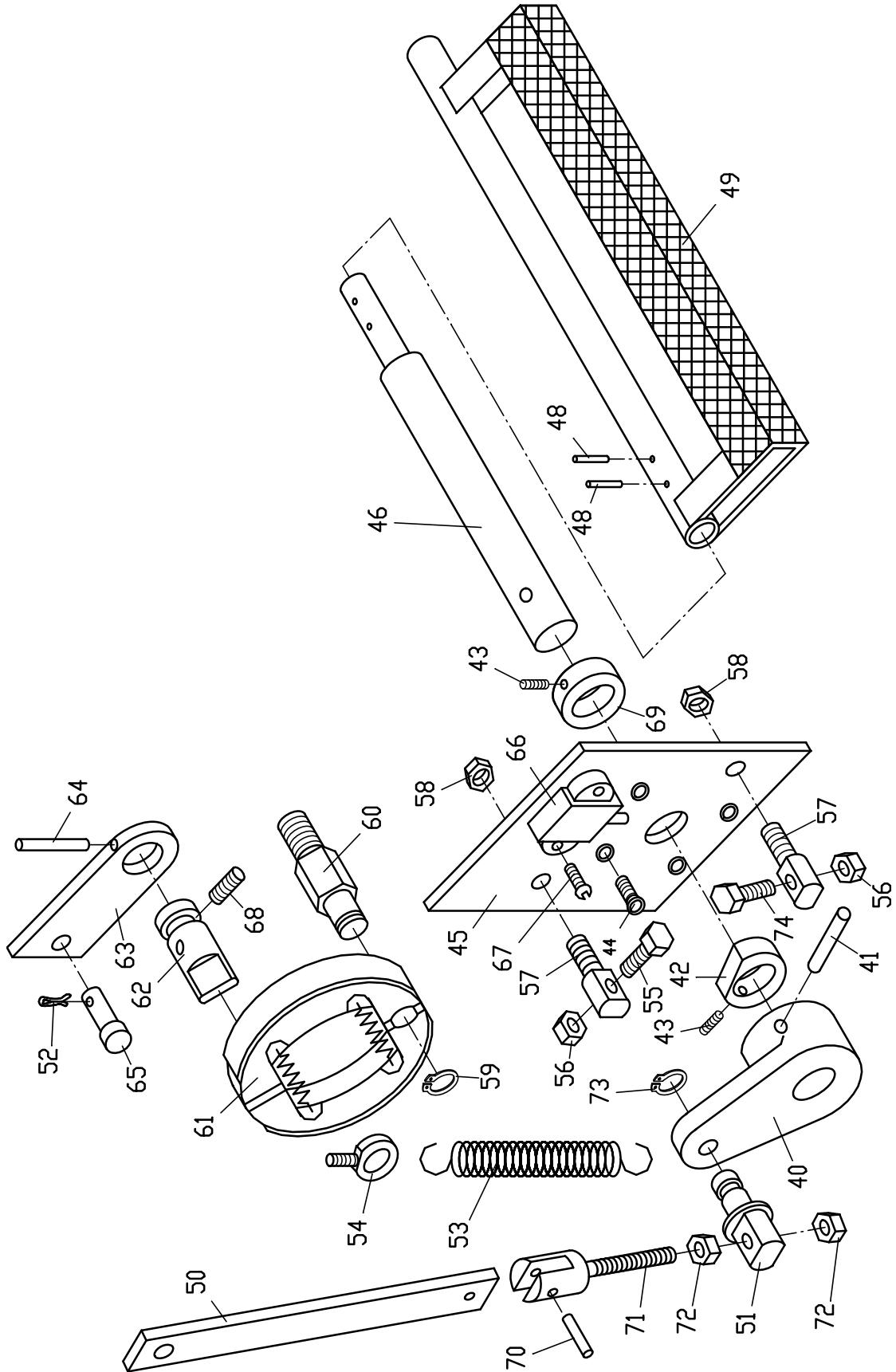

## Brake Assembly

Index No.	Part No.	Description	Size	Qty.
40	ZX-22101-G	Fork		1
41	ZX-S41	Spring Pin	8x40	1
42	ZX-22703	Butt Nail Support		1
43	TS-1524021	Socket Set Screw	M8x10	1
44	ZX-S44	Cross Head Screw	M5x20	4
45	ZX-22714	Positioning Plate		1
46	ZX-22704A	Driving Shaft-Longer		1
48	ZX-S48	Spring Pin	5x30	2
49	ZX-22712A	Pedal (for 1440/1640/1840ZX, serial # 070820ZX1737 and lower)		1
	ZX-22712AE	Pedal (for 1440/1640/1840ZX, serial # 070916ZX1738 and higher)		1
	ZX-22712B	Pedal (for 1460/1660/1860ZX, serial # 070820ZX1737 and lower)		1
	ZX-22712BE	Pedal (for 1460/1660/1860ZX, serial # 070916ZX1738 and higher)		1
	ZX-22712C	Pedal (for 1880/2280ZX, serial # 070820ZX1737 and lower)		1
	ZX-22712CE	Pedal (for 1880/2280ZX, serial # 070916ZX1738 and higher)		1
50	ZX-22710A-G	Draw Bar (for 14" models)		1
	ZX-22710B-G	Draw Bar (for 16" models)		1
	ZX-22710C-G	Draw Bar (for 18" models)		1
	GH2280ZX-22710-G	Draw Bar (for 22" model)		1
51	ZX-22706	Connecting Shaft		1
52	ZX-S52	Split Pin	2x20	2
53	ZX-S53	Tensile Spring	3.5x26x190	1
54	ZX-S54	Eyebolt	M8	1
55	TS-1490091	Hex Cap Bolt	M8x50	1
56	TS-1540061	Hex Nut	M8	1
57	ZX-22707A	Butt Rod Support		1
58	TS-1540072	Hex Nut	M10	1
59	ZX-S59	C-Clip	8	1
60	ZX-22701	Positioning Shaft		1
61	ZX-S61	Brake Shoe		1
62	ZX-22702	Brake Shaft		1
63	ZX-22708	Connecting Plate		1
64	ZX-S64	Elastic Pin	5x25	1
65	ZX-22709	Connecting Shaft		1
66	ZX-S66	Stroke Switch		1
67	ZX-S67	Screw	M4x25	2
68	ZX-S68	Cylindrical End Set Screw	M5x10	1
69	ZX-22711	Butt Nail Support		1
70	ZX-S70	Pin	5n6x20	1
71	ZX-22715	Adjust Bolt		1
72	TS-1540061	Hex Nut	M8	1
73	ZX-S73	C-Clip	12	2
74	TS-149006	Hex Cap Screw	M8x35	1

# Bed Assembly

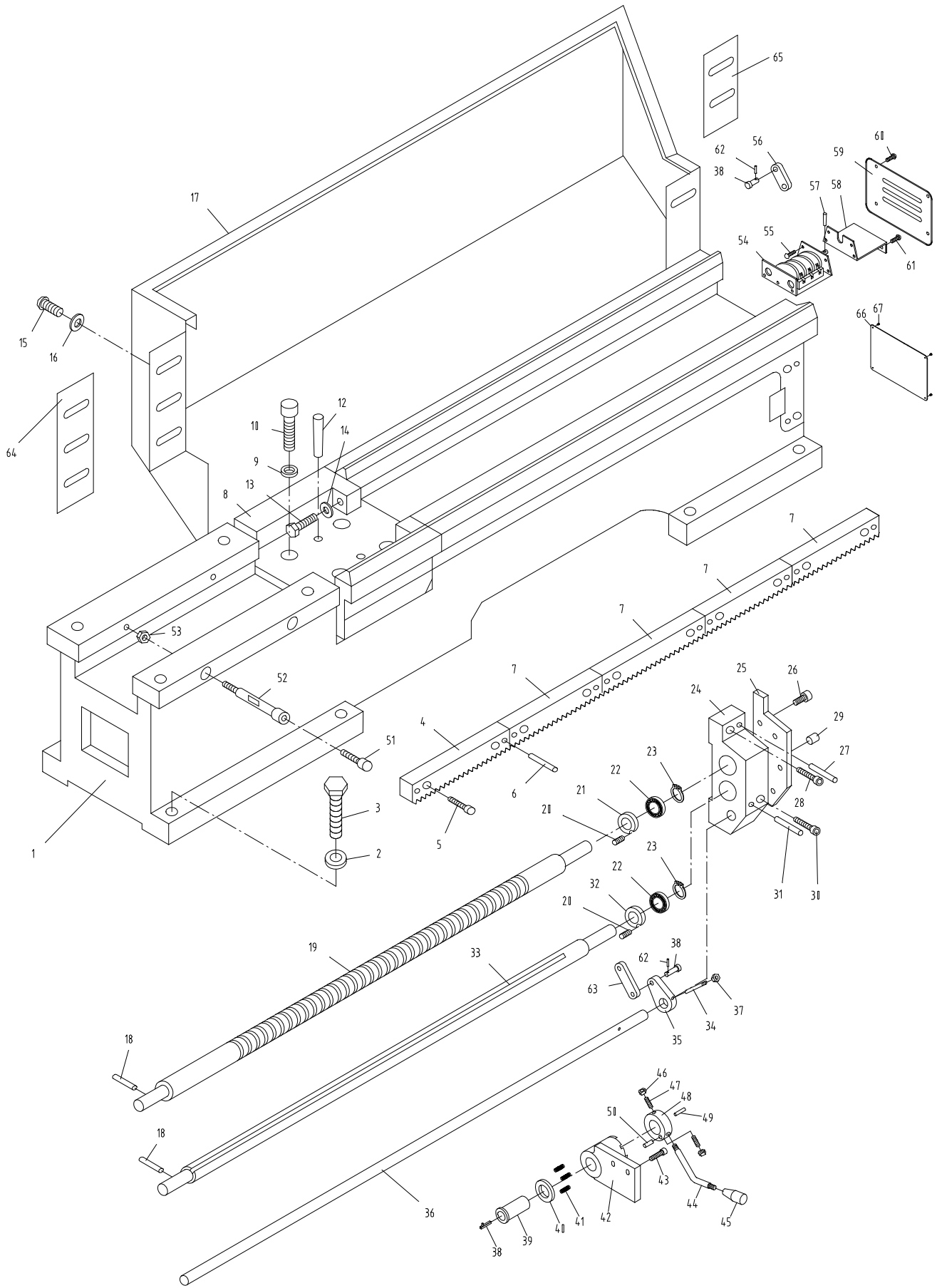



## Bed Assembly

Index No.	Part No.	Description	Size	Qty.
1	ZX-01104A-G	Bed (for 1440/1640/1840ZX)		1
	ZX-01104B-G	Bed (for 1460/1660/1860ZX)		1
	ZX-01104C-G	Bed (for 1880/2280ZX)		1
2	TS-1550101	Flat Washer	M16	8
3	ZX-B3	Hex Cap Bolt	M16x50	8
4	ZX-01706	Rack		1
5	TS-1505051	Hex Socket Cap Screw (for 1440/1640/1840ZX)	M10x35	10
		Hex Socket Cap Screw (for 1460/1660/1860ZX)	M10x35	14
		Hex Socket Cap Screw (for 1880/2280ZX)	M10x35	18
6	ZX-B6	Taper Pin (for 1440/1640/1840ZX)	8x50	10
		Taper Pin (for 1460/1660/1860ZX)	8x50	14
		Taper Pin (for 1880/2280ZX)	8x50	18
7	ZX-01706A	Rack (for 1440/1640/1840ZX)		4
		Rack (for 1460/1660/1860ZX)		6
		Rack (for 1880/2280ZX)		8
8	ZX-01112-G	Saddle		1
9	TS-1551081	Lock Washer	M12	4
10	TS-1506091	Hex Socket Cap Screw	M12x55	4
12	ZX-B12	Thread Taper Pin	12x70	2
13	TS-1491101	Hex Cap Bolt	M10x55	2
14	TS-1550071	Washer	M10	2
15	TS-1503021	Hex Socket Cap Screw	M8x12	5
16	TS-1550041	Washer	M8	5
17	ZX-01741A-G	Splash Guard (for 1440ZX)		1
	ZX-01741B-G	Splash Guard (for 1460ZX)		1
	ZX-01741C-G	Splash Guard (for 1640ZX)		1
	ZX-01741D-G	Splash Guard (for 1660ZX)		1
	ZX-01741E-G	Splash Guard (for 1840ZX)		1
	ZX-01741F-G	Splash Guard (for 1860ZX)		1
	ZX-01741G-G	Splash Guard (for 1880ZX)		1
	GH2280ZX-12701-G	Splash Guard (for 2280ZX)		1
18	ZX-B18	Shear Pin	5x35	2
19	ZX-01708A	Lead Screw (for 40" models, serial # 010611ZX349 and lower)		1
	ZX-01708AN	New Lead Screw (for 40" models, serial # 010618ZX350 and higher)		1
	ZX-01708B	Lead Screw (for 60" models, serial # 010611ZX349 and lower)		1
	ZX-01708BN	New Lead Screw (for 60" models, serial # 010618ZX350 and higher)		1
	ZX-01708C	Lead Screw (for 80" models, serial #010611ZX349 and lower)		1
	ZX-01708CN	New Lead Screw (for 80" models, serial #010618ZX350 and higher)		1
20	ZX-B20	Flat End Set Screw	M6x10	2
21	ZX-01109	Sleeve (serial # 010611ZX349 and lower)		1
	ZX-01109N	New Sleeve (serial # 010618ZX350 and higher)		1
22	ZX-1204	Double Row Spherical Ball Bearing	20x47x14	2
23	ZX-B23	C-Clip	20	2
24	ZX-01110	Bracket (serial # 010611ZX349 and lower)		1
	ZX-01110N-G	New Bracket (serial # 010618ZX350 and higher)		1
25	ZX-01111-G	Cover		1
26	TS-1503041	Hex Socket Cap Screw	M6x16	4
27	ZX-B27	Taper Pin	6x60	1
28	TS-1505081	Socket Cap Screw	M10x50	1
29	ZX-B29	Oil Cup	10	2
30	GH2280ZX-1230	Socket Cap Screw	M10x100	1
31	ZX-B31	Taper Pin	6x100	1
32	ZX-01108	Sleeve (serial # 010611ZX349 and lower)		1
	ZX-01108N	New Sleeve (serial # 010618ZX350 and higher)		1

Index No.	Part No.	Description	Size	Qty.
33	ZX-01709A	Feed Rod (for 40" models, serial # 010611ZX349 and lower)		1
	ZX-01709AN	New Feed Rod (for 40" models, serial # 010618ZX350 and higher)		1
	ZX-01709B	Feed Rod (for 60" models, serial # 010611ZX349 and lower)		1
	ZX-01709BN	New Feed Rod (for 60" models, serial # 010618ZX350 and higher)		1
	ZX-01709C	Feed Rod (for 80" models, serial # 010611ZX349 and lower)		1
	ZX-01709CN	New Feed Rod (for 80" models, serial # 010618ZX350 and higher)		1
34	ZX-B34	Taper Pin	5x30	1
35	ZX-01107-G	Poking Block		1
36	ZX-01707A	Control Rod (for 1440/1640/1840ZX)		1
	ZX-01707B	Control Rod (for 1460/1660/1860ZX)		1
	ZX-01707C	Control Rod (for 1880/2280ZX)		1
37	TS-1540031	Nut	M5	1
38	ZX-06720	Small Shaft		2
39	ZX-06001C-3	Sleeve		1
40	ZX-06001C-2	Spacer		1
41	ZX-B41	Spring	1x75x25	3
42	ZX-06001C-1-G	Bracket		1
43	TS-1504031	Hex Socket Cap Screw	M8x16	2
44	ZX-B44	Lever		1
45	ZX-06001C-4	Long Lever Sleeve		1
46	ZX-B46	Hex Nut	M8	2
47	ZX-B47	Set Screw	M8x28	2
48	ZX-06001C-5	Direction Change Ring		1
49	ZX-B49	Pin	8n6x20	1
50	ZX-B50	Taper Pin	3x20	1
51	TS-1505081	Socket Cap Screw	M10x50	2
52	ZX-05741	Threaded Tube		2
53	TS-1540081	Hex Nut	M12	2
54	ZX-B54	Drum Switch		1
55	ZX-S27	Cross Head Screw	M5x8	5
56	ZX-01718	Rocker		1
57	ZX-B57	Pin	3x16	1
58	ZX-01716-G	Bracket		1
59	ZX-01715C-G	Cover		1
60	ZX-B60	Cross Recessed Pan Head Screw	M6x18	4
61	TS-1482031	Hex Cap Bolt	M6x16	2
62	ZX-B62	Pin	2x15	2
63	ZX-01719-G	Rocker		1
64	ZX-LRG14	Rubber Washer (for 14" models)		1
	ZX-LRG16	Rubber Washer (for 16" models)		1
	ZX-LRG18	Rubber Washer (for 18" models)		1
	ZX-LRG22	Rubber Washer (for 22" models)		1
65	ZX-RRG	Rubber Washer		1
66	1440R~1880R-01305	Plate (serial # 160401ZX3031 and lower)		1
	1440R~1880R-01305-5	Plate (serial # 160410ZX3032 and higher)		1
67	GB827-2x3	Rivet	2x3	4

# Headstock Assembly I

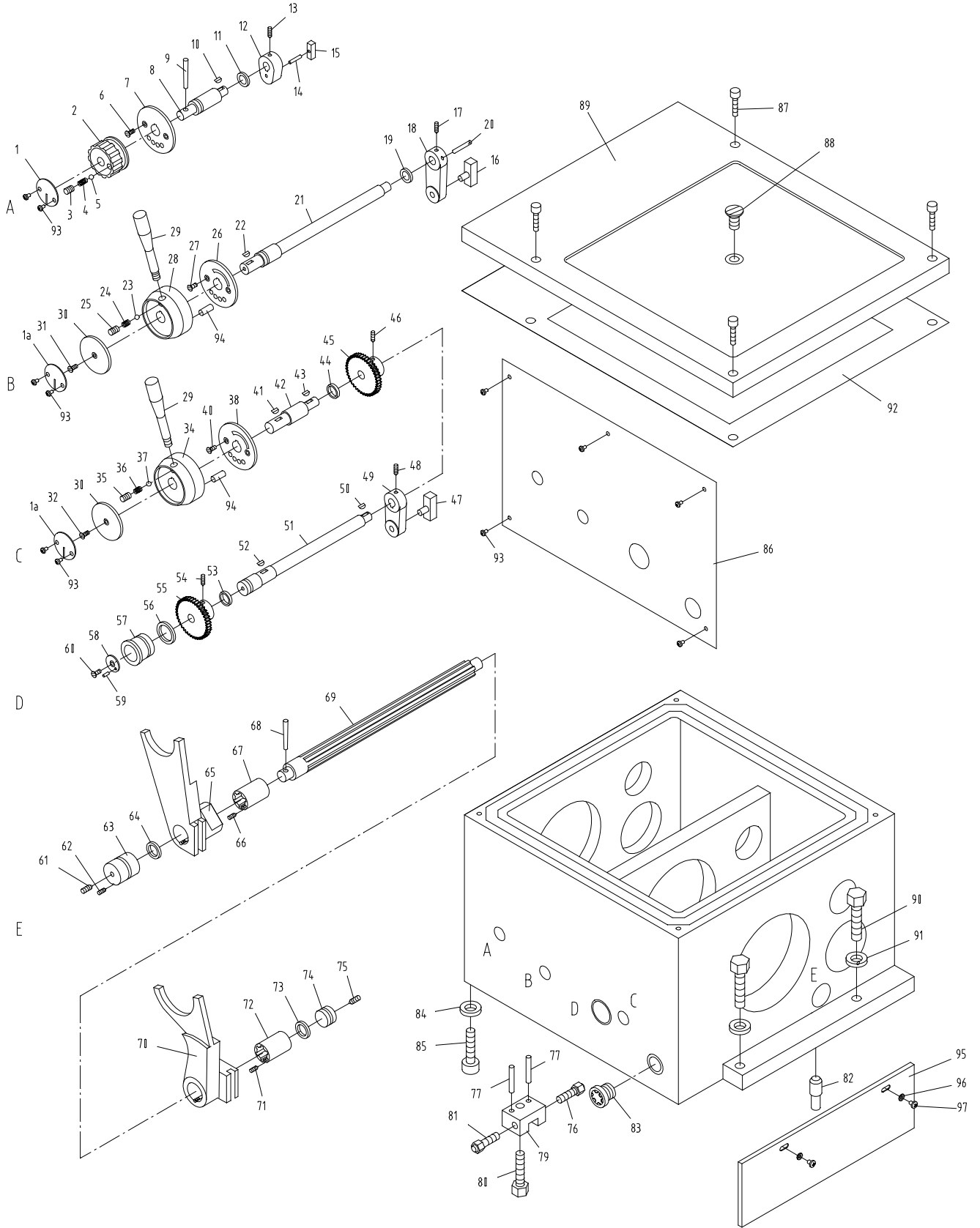

## Headstock Assembly I

Index No.	Part No.	Description	Size	Qty.
1	ZX-02306	Round Sign Plate (serial # 160401ZX3031 and lower)		1
	C6136ZK-02304-1	Round Sign Plate (serial # 160410ZX3032 and higher)		1
1a	ZX-02306	Round Sign Plate (serial # 160401ZX3031 and lower)		2
	14~18R-02303-2	Round Sign Plate (serial # 160410ZX3032 and higher)		2
2	ZX-02122-G	Positioning Handle		1
3	ZX-H3	Flat End Set Screw	M10x12	1
4	ZX-H4	Spring	YI-1x8x25	1
5	ZX-H5	Steel Ball	8	1
6	ZX-H6	Countersunk Head Screw	M5x12	2
7	ZX-02743-G	Positioning Disc		1
8	ZX-02738	Shaft		1
9	ZX-H9	Taper Pin	5x55	1
10	ZX-H10	Woodruff Key	4x16	1
11	ZX-H11	Ring Seal	25x2.4	1
12	ZX-02116	Crank		1
13	TS-1523051	Set Screw	M6x16	1
14	ZX-H14	Pin	5n6x28	1
15	ZX-02302	Poking Block		1
16	ZX-02738C	Pin Block		1
17	TS-1523051	Set Screw	M6x16	1
18	ZX-02114	Crank		1
19	ZX-H11	Ring Seal	25x2.4	1
20	ZX-H20	Pin	5x30	1
21	ZX-02734	Shaft		1
22	ZX-H10	Woodruff Key	4x16	1
23	ZX-H5	Steel Ball	8	1
24	ZX-H4	Spring	YI-1x8x25	1
25	ZX-H3	Flat End Set Screw	M10x12	1
26	ZX-02733-G	Left Positioning Disc		1
27	ZX-H6	Countersunk Head Screw	M5x12	2
28	ZX-02113-G	Left Lever Support		1
29	ZX-02741	Handle		2
30	ZX-02732	Cover		2
31	ZX-H6	Countersunk Head Screw	M5x12	1
32	ZX-H6	Countersunk Head Screw	M5x12	1
34	ZX-02119-G	Right Lever Support		1
35	ZX-H3	Flat End Set Screw	M10x12	1
36	ZX-H4	Spring	YI-1x8x25	1
37	ZX-H5	Steel Ball	8	1
38	ZX-02728-G	Right Positioning Disc		1
40	ZX-H6	Countersunk Head Screw	M5x12	2
41	ZX-H10	Woodruff Key	4x16	1
42	ZX-02727	Shaft		1
43	ZX-H10	Half Circle Key	4x16	1
44	ZX-H11	Ring Seal	25x2.4	1
45	ZX-02730	Gear	1.5m36T	1
46	TS-1523051	Set Screw	M6x16	1
47	ZX-02738C	Pin Block		1
48	TS-1523051	Set Screw	M6x16	1
49	ZX-02111	Crank		1
50	ZX-H10	Woodruff Key	4x16	1
51	ZX-02731/1	Control Shaft		1
52	ZX-H10	Woodruff Key	4x16	1
53	ZX-H11	Ring Seal	25x2.4	1
54	ZX-H54	Taper End Set Screw	M6x16	1

Index No.	Part No.	Description	Size	Qty.
55	ZX-02732/2	Gear	1.5m36T	1
56	ZX-H56	Ring Seal	40x3.1	1
57	ZX-02110	Bushing		1
58	ZX-02729	Cover		1
59	ZX-H59	Pin	3n6x10	1
60	ZX-H6	Countersunk Head Screw	M5x12	1
61	ZX-H61	Countersunk Head Screw	M8x12	1
62	ZX-H62	Flat End Set Screw	M8x12	1
63	ZX-02115	Bearing Support		1
64	ZX-H64	Ring Seal	40x3.1	1
65	ZX-02115	Left Fork		1
66	ZX-H66	Flat End Set Screw	M6x10	1
67	ZX-02120A/2	Bushing		1
68	ZX-H68	Taper Pin	6x35	1
69	ZX-02736	Control Shaft		1
70	ZX-02112	Right Fork		1
71	ZX-H66	Flat End Set Screw	M6x10	1
72	ZX-02120A/2	Bushing		1
73	ZX-H73	Ring Seal	30x3.1	1
74	ZX-02735	Blocking Piece		1
75	ZX-H61	Countersunk Head Screw	M8x12	1
76	ZX-02744	Adjusting Screw		1
77	ZX-H77	Taper Pin	8x40	2
79	ZX-92124	Adjusting Block		1
80	ZX-H80	Hex Cap Bolt	M12x50	1
81	ZX-02744	Adjusting Screw		1
82	ZX-02736C	Positioning Pin		1
83	ZX-H83	Oil Sight Glass		1
84	ZX-H84	Washer	A16	2
85	ZX-H85	Hex Socket Cap Screw	M16x50	2
86	ZX-02301A	Label (for 1440ZX) (serial #110915ZX2363 and lower)		1
	ZX-02301AJ	Label (for 1440ZX) (serial #160401ZX3031 and lower)		1
	ZX-02301-298	Label (for 1440ZX) (serial #160410ZX3032 and higher)		1
	ZX-02301B	Label (for 1460ZX) (serial #110915ZX2363 and lower)		1
	ZX-02301BJ	Label (for 1460ZX) (serial #160401ZX3031 and lower)		1
	ZX-02301-298	Label (for 1460ZX) (serial #160410ZX3032 and higher)		1
	ZX-02301C	Label (for 1640ZX) (serial #110915ZX2363 and lower)		1
	ZX-02301CJ	Label (for 1640ZX) (serial #160401ZX3031 and lower)		1
	ZX-02301-299	Label (for 1640ZX) (serial #160410ZX3032 and higher)		1
	ZX-02301D	Label (for 1660ZX) (serial #110915ZX2363 and lower)		1
	ZX-02301DJ	Label (for 1660ZX) (serial #160401ZX3031 and lower)		1
	ZX-02301-299	Label (for 1660ZX) (serial #160410ZX3032 and higher)		1
	ZX-02301E	Label (for 1840ZX) (serial #110915ZX2363 and lower)		1
	ZX-02301EJ	Label (for 1840ZX) (serial #160401ZX3031 and lower)		1
	ZX-02301-300	Label (for 1840ZX) (serial #160410ZX3032 and higher)		1
	ZX-02301F	Label (for 1860ZX) (serial #110915ZX2363 and lower)		1
	ZX-02301FJ	Label (for 1860ZX) (serial #160401ZX3031 and lower)		1
	ZX-02301-300	Label (for 1860ZX) (serial #160410ZX3032 and higher)		1
	ZX-02301G	Label (for 1880ZX) (serial #110915ZX2363 and lower)		1
	ZX-02301GJ	Label (for 1880ZX) (serial #160401ZX3031 and lower)		1
	ZX-02301-300	Label (for 1880ZX) (serial #160410ZX3032 and higher)		1
	GH2280ZX-02301	Label (for 2280ZX) (serial #110915ZX2363 and lower)		1
	GH2280ZX-02301J	Label (for 2280ZX) (serial #160401ZX3031 and lower)		1
	GH2280ZX-02301m-22	Label (for 2280ZX) (serial #160410ZX3032 and higher)		1
87	TS-1504071	Hex Socket Cap Screw	M8x35	4
88	ZX-H88	Countersunk Head Screw	M16x25	1
89	ZX-02117-G	Top Cover		1
90	ZX-H90	Hex Cap Bolt		2
91	ZX-H91	Washer	A16	2

<b>Index No.</b>	<b>Part No.</b>	<b>Description</b>	<b>Size</b>	<b>Qty.</b>
92	ZX-02505	Paper Gasket		1
93	TS-1531012	Slotted Pan Head Screw (serial #160401ZX3031 and lower)	M3x6	7
	GB2672-M3x6	Screw (serial #160410ZX3032 and higher)	M3x6	11
94	ZX-H94N	Pin	4n6x15	2
95	ZX-02740	Front Cover		1
96	GB97.2-6	Washer	6	2
97	GB818-M6x8	Cross Head Screw	M6x8	2

# Headstock Assembly II

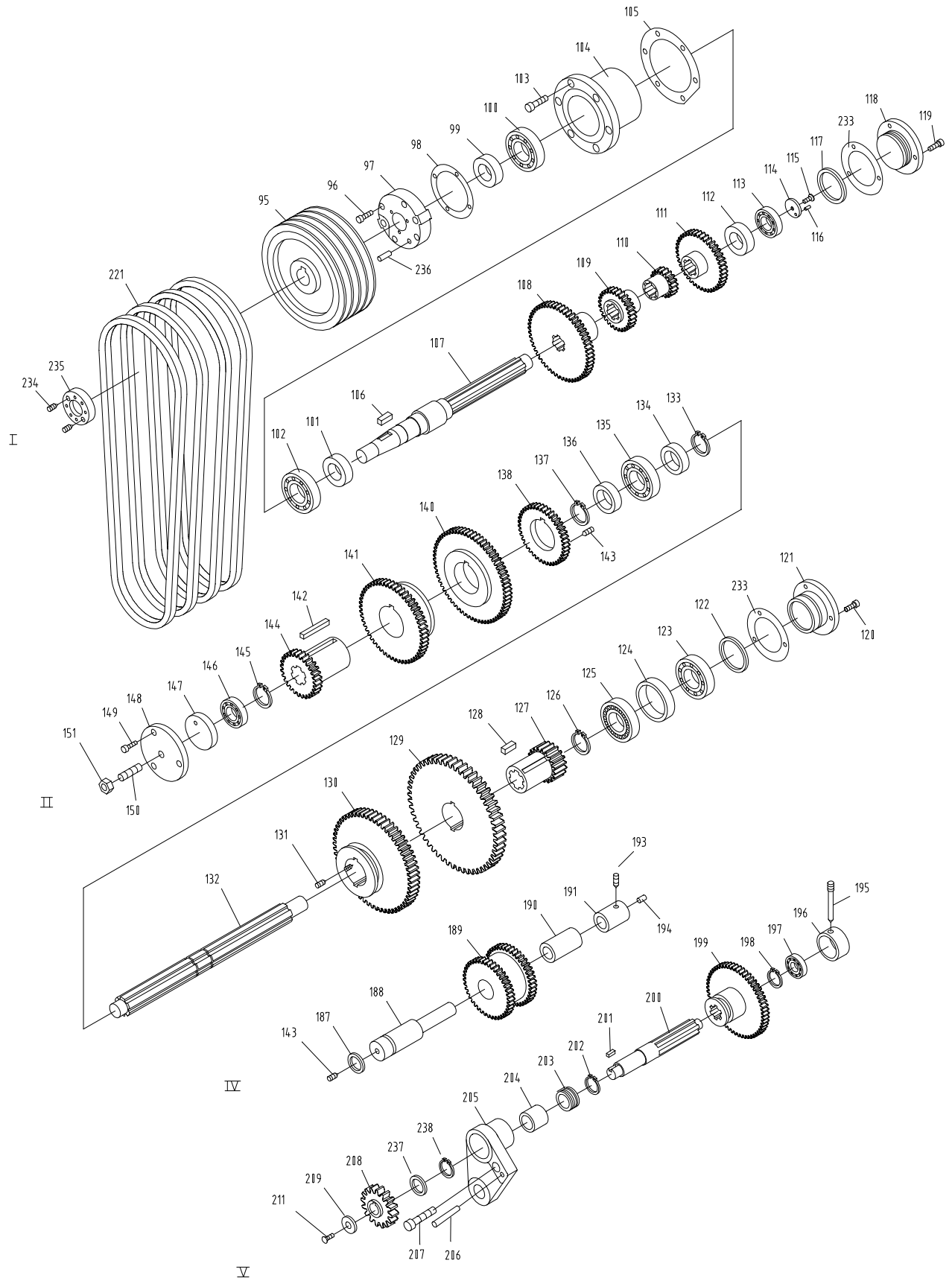

## Headstock Assembly II

Index No.	Part No.	Description	Size	Qty.
95	ZX-02107	Pulley		1
96	TS-1503061	Socket Cap Screw	M6x25	4
97	ZX-02106	Bearing Cover		1
98	ZX-02506	Gasket		1
99	ZX-H99	Ring Seal	32x52	1
100	BB-6207/P5	Ball Bearing	35x72x17	1
101	ZX-H102	Sleeve	30x10	1
102	BB-6207/P5	Ball Bearing	35x72x17	1
103	TS-1504051	Socket Cap Screw	M8x25	6
104	ZX-02105	Bearing Support		1
105	ZX-02502	Gasket		1
106	ZX-H106	Flat Key	10x8x35	1
107	ZX-02709	Shaft		1
108	ZX-02754X	Gear (for 14" models)	2.5m52T	1
	ZX-02754X/6P	Gear (for 16"/18"/22" models)	2.5m61T	1
109	ZX-02753X	Gear (for 14" models)	2.5m28T	1
	ZX-02753X/6P	Gear (for 16"/18"/22" models)	2.5m32T	1
110	ZX-02752X	Gear	2.5m18T	1
111	ZX-02751X	Gear (for 14" models)	2.5m41T	1
	ZX-02751X/6P	Gear (for 16"/18"/22" models)	2.5m47T	1
112	ZX-H112	Sleeve		1
113	BB6305/P5	Ball Bearing	25x62x17	1
114	ZX-H114	Shaft End Lock Ring	32	1
115	ZX-H115	Countersunk Head Screw	M6x20	1
116	ZX-H59	Pin	3n6x10	1
117	ZX-H117	Ring Seal	60x3.1	1
118	ZX-02104-G	Blocking Flange		1
119	TS-1503041	Socket Cap Screw	M6x15	3
120	TS-1503041	Socket Cap Screw	M6x15	3
121	ZX-02103	Blocking Flange (serial #110710ZX2337 and lower)		1
	ZX-19101-G	Blocking Flange (serial #110825ZX2338 and higher)		1
122	ZX-H117	Ring Seal	60x3.1	1
123	BB-6305/P5	Ball Bearing	25x62x17	1
124	ZX-H124	Sleeve	62x6	1
125	BB-6305/P5	Ball Bearing	25x62x17	1
126	ZX-H126	Circle Clip For Shaft	35	1
127	ZX-02705	Gear	3m19T	1
128	ZX-H128	Flat Key	8x7x50	2
129	ZX-02706	Gear	3m67T	1
130	ZX-02707	Gear	3m59T	1
131	ZX-H62	Flat End Set Screw	M8x12	1
132	ZX-02708	Shaft		1
133	ZX-H133	C-Clip	35	1
134	ZX-H134	Sleeve	35x8	1
135	BB-6007/P5	Ball Bearing	35x62x14	1
136	ZX-H134	Sleeve	35x8	1
137	ZX-H133	C-Clip	35	1
138	ZX-02756	Gear (for 14" models)	2.5m42T	1
	ZX-02756/6P	Gear (for 16"/18"/22" models)	2.5m36T	1
140	ZX-02757	Gear (for 14" models)	2.5m65T	1
	ZX-02757/6P	Gear (for 16"/18"/22" models)	2.5m65T	1
141	ZX-02758	Gear (for 14" models)	2.5m55T	1
	ZX-02758/6P	Gear (for 16"/18"/22" models)	2.5m51T	1
142	ZX-H142	Flat Key	10x6x60	2



Index No.	Part No.	Description	Size	Qty.
143	ZX-H143	Flat Head Set Screw	M8x12	2
144	ZX-02755X	Gear (for 14" models)	2.5m31T	1
	ZX-02755X/6P	Gear (for 16"/18"/22" models)	2.5m22T	1
145	ZX-H133	C-Clip	35	1
146	BB-6305	Ball Bearing	25x62x17	1
147	ZX-H147	Pushing Disc	62	1
148	ZX-02109C	Cover		1
149	TS-1503041	Socket Cap Screw	M6x15	3
150	ZX-H150	Set Screw	M12x65	1
151	ZX-H151	Hex Nut	M12	1
187	ZX-H187	Ring Seal	35x3.1	1
188	ZX-02714	Shaft		1
189	ZX-02716	Double Gear	2m48T	1
190	ZX-02303	Copper Sleeve		1
191	ZX-02734C	Positioning Sleeve		1
193	TS-1524041	Set Screw	M8x15	1
194	ZX-02733C	Blocking Piece		1
195	ZX-02718	Taper End Set Screw		1
196	ZX-02114C	Sleeve		1
197	BB-6203	Ball Bearing	17x40x12	1
198	ZX-H198	C-Clip	28	1
199	ZX-02717	Gear	2m65T	1
200	ZX-02715	Shaft		1
201	ZX-H201	Flat Key	5x5x1	1
202	ZX-H198	C-Clip	28	1
203	ZX-02722C	Sleeve		1
204	ZX-02301	Oil Bushing (serial # 101029ZX2256 and lower)		1
	CDL50002302	Oil Bushing (serial # 101214ZX2257 and higher)		1
205	ZX-08106A-G	Bracket (for Shaft V, Vb) (for 14"/16" models)		1
	ZX-08106B-G	Bracket (for Shaft V, Vb) (for 18" models)		1
	GH2280ZX-08106-G	Bracket (for Shaft V, Vb, Vc) (for 22" model)		1
206	ZX-H77	Taper Pin	8x40	1
207	TS-1505031	Hex Socket Cap Screw	M10x25	1
208	TNMP-08706A(N)	Gear (for 14"/16"/22" models)	3.5m16T	1
	TNMP-08706B(N)	Gear (for 18" models)	4m16T	1
209	ZX-02724C	Washer		1
210	ZX-H59	Pin	3n6x10	1
211	ZX-H211	Countersunk Head Screw	M5x16	1
221	VB-A75	V-Belt (for 14" models)	A-75	4
	VB-A76	V-Belt (for 16" models)	A-76	4
	VB-A77	V-Belt (for 18" models)	A-77	4
	VB-A85	V-Belt (for 22" model)	A-85	4
233	ZX-02506	Paper Gasket		2
234	ZX-H234	Set Screw	M8x6	2
235	ZX-02743N	Clamping Round Nut		1
236	ZX-H236	Pin	8x30	2
237	ZXH237	Seal Ring (serial # 101214ZX2257 and higher)	25x40x70	1
238	ZXH238	Steel C-clip (serial # 101214ZX2257 and higher)	32	1

# Headstock Assembly III

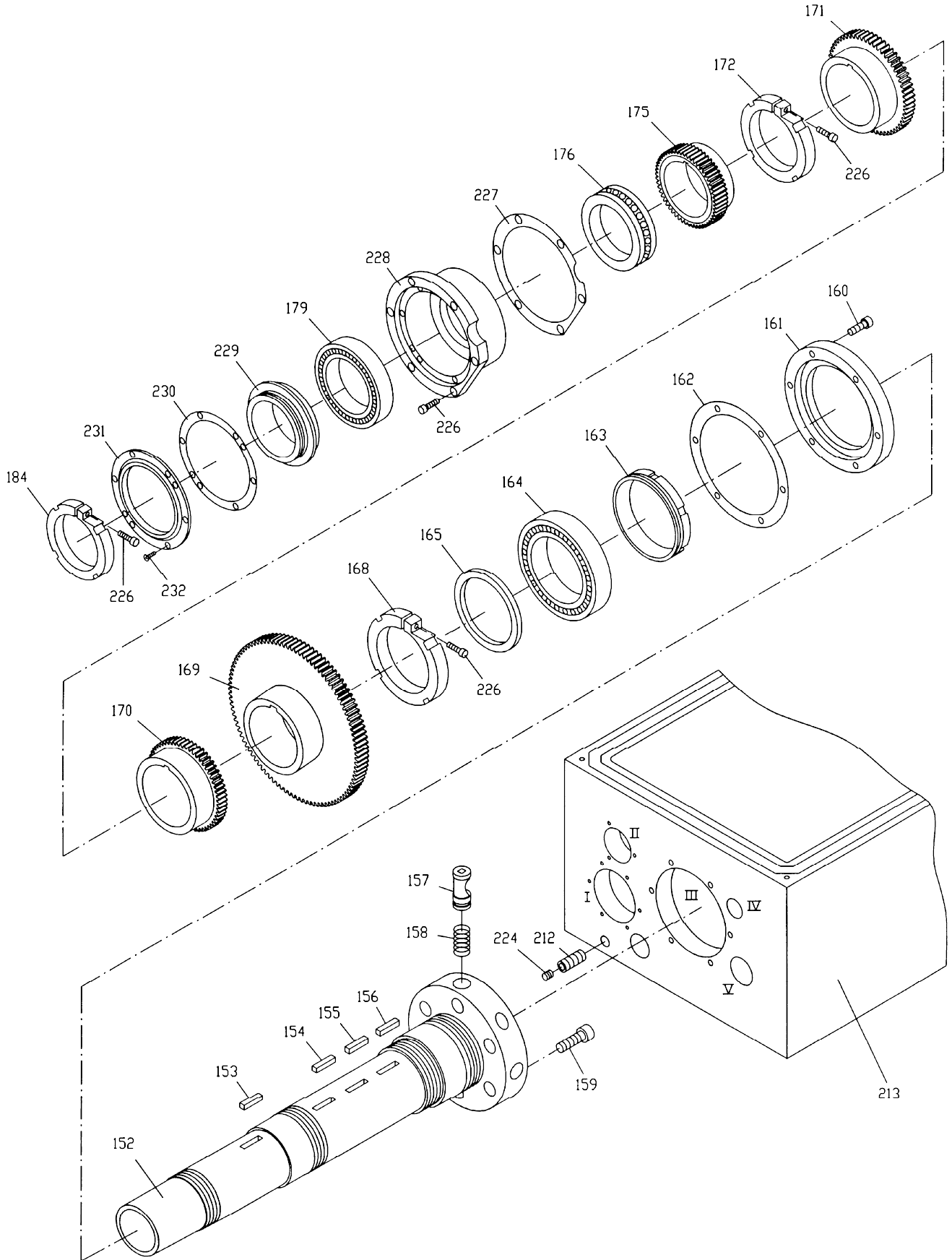

### Headstock Assembly III

Index No.	Part No.	Description	Size	Qty.
152	ZX-02704	Spindle		1
153	ZX-H153	Flat Key	10x8x40	1
154	ZX-H154	Flat Key	10x8x50	1
155	ZX-H155	Flat Key	12x8x50	1
156	ZX-H156	Flat Key	14x9x50	1
157	ZX-02701	Cam Lock		6
158	ZX-H158	Spring	1x8x25	6
159	ZX-02703	Cam Positioning Screw		6
160	TS-1505041	Hex Socket Cap Screw	M10x28	6
161	ZX-02102-G	Bearing Front Cover		1
162	ZX-02501	Gasket		1
163	ZX-02702	Oil Splashing Ring		1
164	NN3024/P5	Taper Roller Bearing	120x180x46	1
165	ZX-02726	Lining		1
168	ZX-02725A	Round Nut w/Screw		1
169	ZX-02723	Gear	3m98T	1
170	ZX-02722	Gear	3m50T	1
171	ZX-02721	Gear	3m58T	1
172	ZX-02720A	Round Nut w/Screw		1
175	ZX-02710	Gear	2m65T	1
176	51120/P5	Thrust Bearing	100x135x25	1
179	BB-7020AC/P5	Angular Bearing	100x150x24	1
184	ZX-02713A	Round Nut w/Screw		1
212	ZX-H212	Drain Plug (14" models, serial # 001204ZX258 and lower)		1
	ZX-H212	Drain Plug (16" models, serial #010312ZX293 and lower, also includes serial # 010319ZX298 and 299)		1
	ZX-H212	Drain Plug (18" models, serial # 010416ZX313 and lower)		1
	ZX-H212A	Drain Plug (14" models, serial # 010105ZX263 and higher)		1
	ZX-H212A	Drain Plug (16" models, serial #010319ZX294 and higher, except for serial # 010319ZX298 and 299)		1
	ZX-H212A	Drain Plug (18" models, serial # 010514ZX323 and higher)		1
	ZX-H212A	Drain Plug (22" model)	Z3/8"	1
213	ZX-02101A	Headstock Casting (14" models, serial # 001204ZX258 and lower)		1
	ZX-02101AN	Headstock Casting (14" models, serial # 010105ZX263 and lower)		1
	ZX-02101AN-G	Headstock Casting (14" models)		1
	ZX-01201B	Headstock Casting (16" models, serial # 010312ZX293 and lower, also includes serial # 110319ZX298 and 299)		1
	ZX-02101BN	Headstock Casting (16" models, serial # 010319ZX294 and lower except for serial # 010319ZX298 and 299)		1
	ZX-02101BN-G	Headstock Casting (16" models)		1
	ZX-02101C	Headstock Casting (18" models, serial # 010416ZX313 and lower)		1
	ZX-02101CN	Headstock Casting (18" models, serial # 010514ZX323 and lower)		1
	ZX-02101CN-G	Headstock Casting (18" models)		1
	GH2280ZX-02101	Headstock Casting (22" model)		1
	GH2280ZX-02101-G	Headstock Casting (22" model)		1
224	ZX-G38-3A	Screw		1
226	ZX-H226	Hex Socket Cap Screw	M8x28	9
227	ZX-02502F	Gasket (The part is canceled from serial # 130415ZX2706)		1
228	ZX-02108F	Bearing Support		1
229	ZX-02711F	Sleeve		1
230	ZX-02510F	Gasket		1
231	ZX-02761F	Bearing Back Cover		1
232	ZX-H232	Screw	M5x10	6

# Headstock Assembly IV

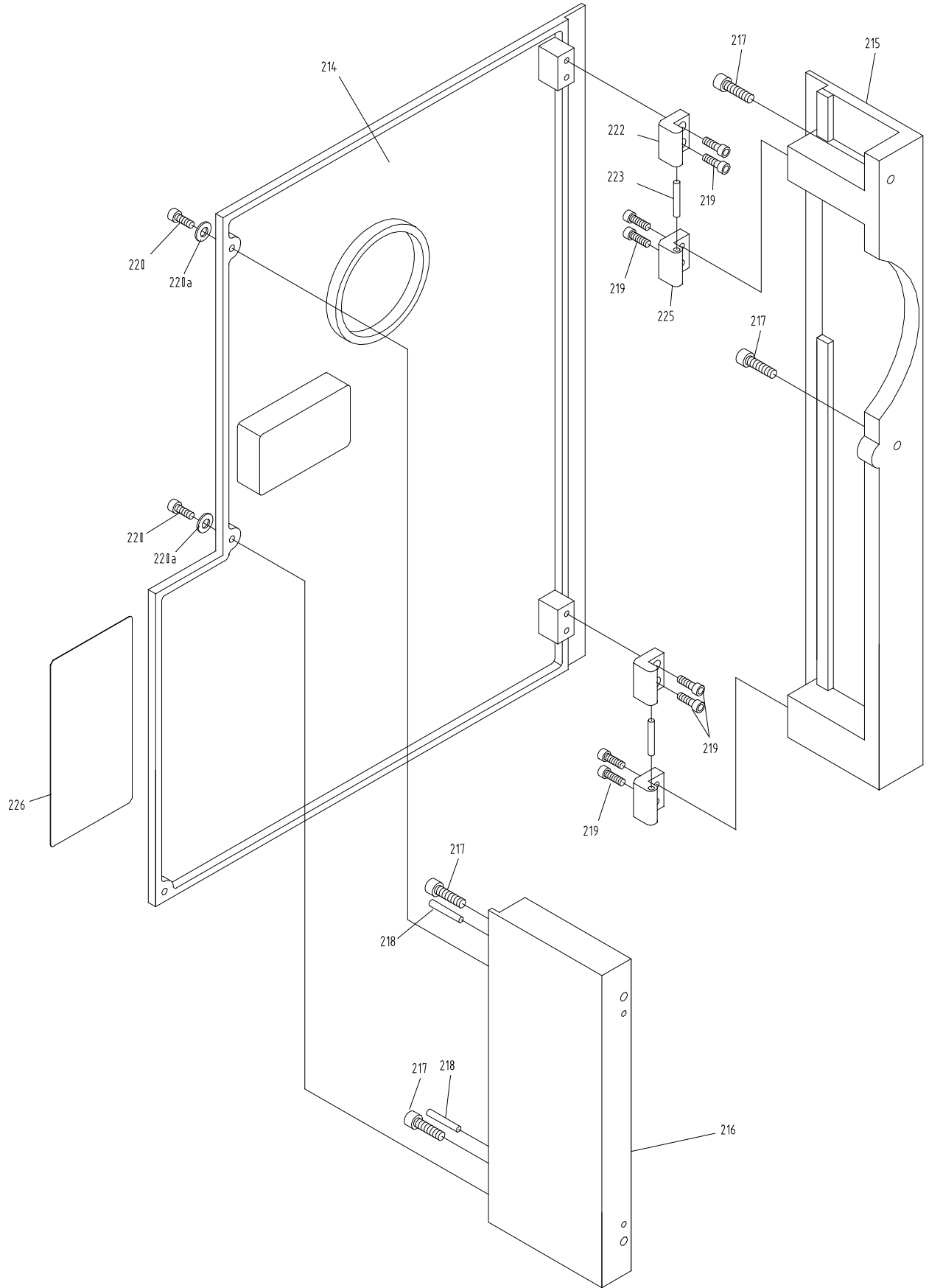

## Headstock Assembly IV

Index No.	Part No.	Description	Size	Qty.
214	ZX-08302A-G	Back Cover (for 14" models)		1
	ZX-08302B-G	Back Cover (for 16" models)		1
	ZX-08302C-G	Back Cover (for 18" models)		1
	GH2280ZX-08301-G	Back Cover (for 22" model)		1
215	ZX-08114A-G	Rear Side Plate (for 14" models)		1
	ZX-08114B-G	Rear Side Plate (for 16" models)		1
	ZX-08114C-G	Rear Side Plate (for 18" models)		1
	GH2280ZX-08114-G	Rear Side Plate (for 22" model)		1
216	ZX-08113A-G	Front Side Plate (for 14" models)		1
	ZX-08113B-G	Front Side Plate (for 16" models)		1
	ZX-08113C-G	Front Side Plate (for 18" models)		1
	GH2280ZX-08113-G	Front Side Plate (for 22" model)		1
217	TS-1504051	Socket Cap Screw	M8x25	4
218	ZX-H218	Taper Pin	6x25	2
219	TS-1503051	Socket Cap Screw	M6x20	8
220	TS-1514021	Socket Cap Screw	M6x15	3
220a	GB97.2-6	Washer	6	3
222	ZX-08712	Upper Hinge		2
223	ZX-H223	Pin	6n6x40	2
225	ZX-08711	Lower Hinge		2
226	GH-1440ZX-11304-6	Warning Plate (serial #160410ZX3032 and higher)		1
	GH-1640ZX-11304-7	Warning Plate (serial #160410ZX3032 and higher)		1
	GH-1660ZX-11304-8	Warning Plate (serial #160410ZX3032 and higher)		1
	GH-1860ZX-11304-9	Warning Plate (serial #160410ZX3032 and higher)		1
	GH-1880ZX-11304-10	Warning Plate (serial #160410ZX3032 and higher)		1
	GH-2280ZX-11304-11	Warning Plate (serial #160410ZX3032 and higher)		1

# Change Gear Box Assembly I

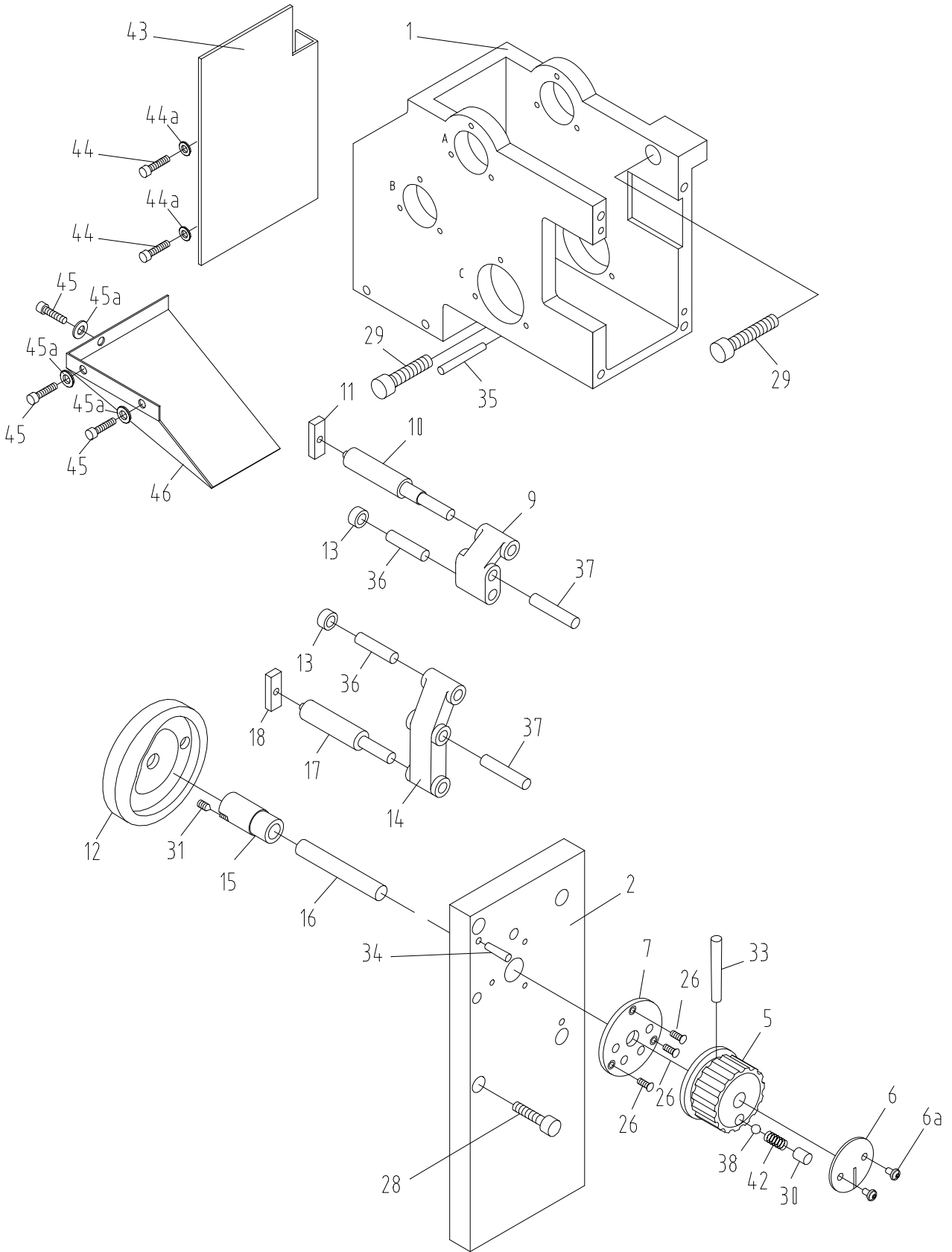

## Change Gear Box Assembly I

Index No.	Part No.	Description	Size	Qty.
1	ZX-08101-G	Change Gear Box Casting		1
2	ZX-08108-G	Front Cover		1
5	ZX-05104C-G	Hand Wheel		1
6	ZX-05301C	Sign Plate (serial #160401ZX3031 and lower)		1
	C6136ZK-02304-1	Sign Plate (serial #160410ZX3032 and higher)		1
6a	GB2672-M3×6	Screw (serial # 160410ZX3032 and higher)	M3×6	2
7	ZX-08708	Positioning Disc		1
9	ZX-08111	Crank		1
10	ZX-08705	Connecting Rod		1
11	ZX-08304	Sliding Block		1
12	ZX-05103C	Cam		1
13	ZX-05702C	Roller		2
14	ZX-08109	Crank		1
15	ZX-08110	Bushing		1
16	ZX-08704	Rotating Shaft		1
17	ZX-08703	Connecting Rod		1
18	ZX-08304	Sliding Block		1
26	ZX-C26	Cross Head Screw	M4x12	3
28	TS-1504051	Socket Cap Screw	M8x25	4
29	TS-1516051	Hex Socket Cap Screw	M10x40	2
30	TS-1525021	Set Screw	M10x12	1
31	ZX-C31	Flat Head Set Screw	M6x8	1
33	ZX-C33	Taper Pin	4x45	1
34	ZX-C34	Taper Pin	6x30	2
35	ZX-C35	Taper Pin	6x50	1
36	ZX-C36	Pin	10m6x40	2
37	ZX-C37	Pin	10m6x50	2
38	ZX-H5	Steel Ball	8	1
42	ZX-C42	Spring	1x8x30	1
43	ZX-08716-G	Splash Guard		1
44	GB818-M6x12	Cross Recessed Pen Head Screw	M6x12	2
44a	GB97.2-6	Washer	6	2
45	GB818-M5x12	Cross Recessed Pen Head Screw	M5x12	3
45a	GB97.2-5	Washer	5	3
46	ZX-08715-G	Splash Guard		1

# Change Gear Box Assembly II

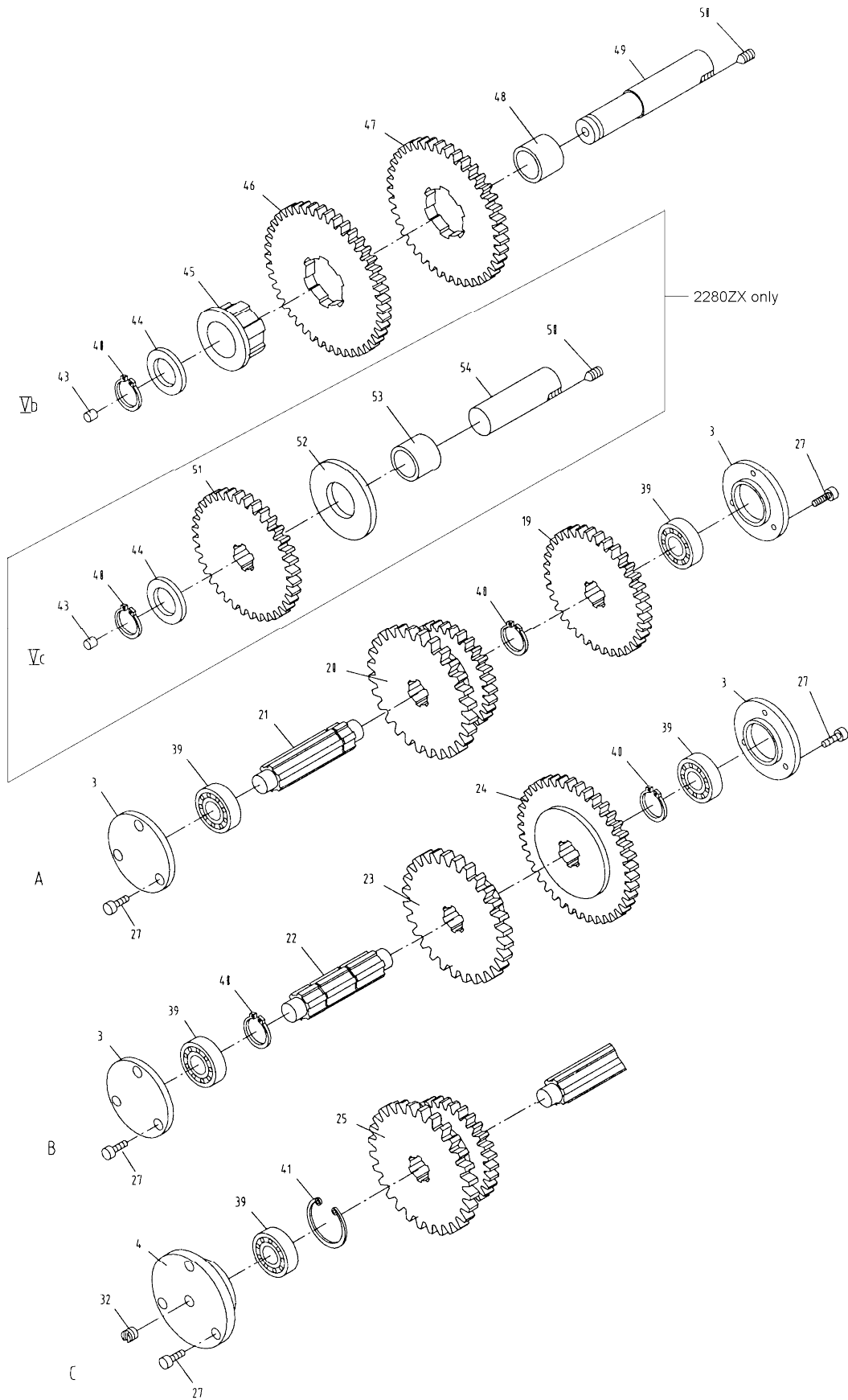



## Change Gear Box Assembly II

Index No.	Part No.	Description	Size	Qty.
3	ZX-08104-G	End Cover		4
4	ZX-08103-G	Bearing Support		1
19	ZX-08107	Gear	3m36T	1
20	ZX-08105	Double Gear	3.75m28T/3m30T	1
21	ZX-08702	Shaft		1
22	ZX-08701	Shaft		1
23	ZX-08710	Gear	3.75m27T	1
24	ZX-08709	Gear	3m41T	1
25	ZX-08102	Double Gear	3.75m30T/3m29T	1
27	ZX-C27	Slotted Cheese Head Screw	M5x12	15
32	ZX-C32	Flat Head Set Screw	M10x12	1
39	BB-6203ZZ/P6	Ball Bearing	17x40x12	5
40	ZX-C40	C-Clip	25	4(5 for 22")
41	ZX-C41	C-Clip	40	1
43	ZX-C43	Oil Cup	8	1 (2 for 22")
44	TNMP08108	Washer		1 (2 for 22")
45	TNMP08102	Splined Sleeve		1
46	TNMP08504	Gear	3m41T	1
47	TNMP08501A	Gear (for 14"/16"/22" models)	3.5m36T	1
	TNMP08501B	Gear (for 18" models)	4m36T	1
48	ZX-05502C	Oil Bushing		1
49	ZX-08707	Shaft Vb		1
50	ZX-C50	Flat Head Set Screw	M8x10	1 (2 for 22")
51	GH2280ZX-08112	Gear (for 22" model)	3m30T	1
52	GH2280ZX-1052	Washer		1
53	GH2280ZX-1053	Oil Bushing		1
54	GH2280ZX-08707	Axis Vc (for 22" model)		1

# Quick Change Gear Box I

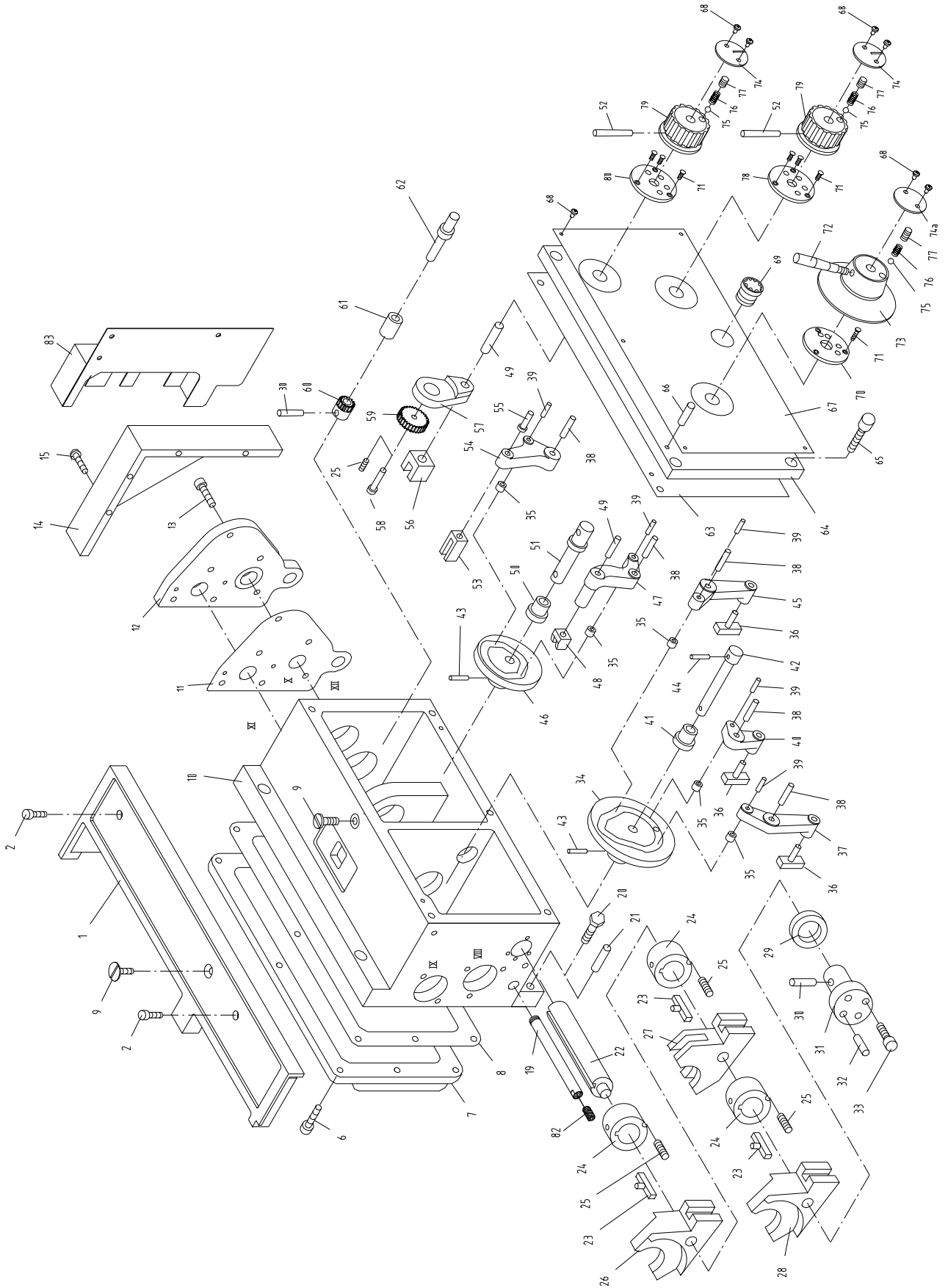

## Quick Change Gear Box I

Index No.	Part No.	Description	Size	Qty.
1	KLS1740A-05152-G	Upper Cover		1
2	TS-1503071	Hex Socket Cap Screw	M6x30	2
6	TS-1504031	Hex Socket Cap Screw	M8x16	10
7	ZX-05109-G	Rear Cover		1
8	ZX-05502	Gasket		1
9	ZX-Q09	Countersunk Head Screw	M10x18	1
10	ZX-05101-G	Feedbox Casting		1
11	ZX-05501	Gasket		1
12	ZX-05108-G	Flange		1
13	TS-1504031	Hex Socket Cap Screw	M8x16	6
14	ZX-05151-G	Extending Plate		1
15	TS-1503131	Hex Socket Cap Screw	M6x60	4
19	ZX-Q19	Pipe	M10x10	1
20	TS-1491061	Hex Cap Bolt	M10x40	2
21	ZX-H68	Taper Pin	6x35	2
22	ZX-05738	Control Shaft		1
23	ZX-05739	Sliding Key		3
24	ZX-05128	Sliding Sleeve		3
25	ZX-Q25	Flat Head Set Screw	M5x8	4
26	ZX-05125	Right Fork		1
27	ZX-05126	Middle Fork		1
28	ZX-05127	Left Fork		1
29	ZX-Q29	Ring Seal	32x3.1	1
30	ZX-Q30	Taper Pin (serial #121220ZX2630 and lower)	4x25	2
	GB877- 4x30	Taper Pin (serial #130102ZX2631 and higher)	4x30	2
31	ZX-05129	Cover		1
32	ZX-Q32	Pin	5n6x15	1
33	ZX-Q33	Cheese Head Screw	M5x16	3
34	ZX-05122	Cam		1
35	ZX-05728	Rolling Sleeve		5
36	ZX-05729	Poking Key		3
37	ZX-05123	Crank		1
38	ZX-Q38	Pin	8n6x32	5
39	ZX-Q39	Pin	6n6x20	5
40	ZX-05124	Crank		1
41	ZX-05111	Sleeve		1
42	ZX-05726	Lever Shaft		1
43	ZX-Q43	Taper Pin (serial #121220ZX2630 and lower)	4x32	2
	GB877- 4x35	Taper Pin (serial #130102ZX2631 and higher)	4x35	2
44	ZX-Q44	Taper Pin	4x65	1
45	ZX-05121	Crank		1
46	ZX-05118	Cam		1
47	ZX-05120	Crank		1
48	ZX-05116	Fork		1
49	ZX-Q49	Pin	8n6x18	2
50	ZX-05117	Sleeve		1
51	ZX-05737	Lever Shaft		1
52	ZX-C33	Taper Pin	4x45	2
53	ZX-05115	Fork		1
54	ZX-05119	Crank		1
55	ZX-05735	Pin		1
56	ZX-05112	Fork		1
57	ZX-05113	Crank		1
58	ZX-05730	Small Shaft		1
59	ZX-05731	Big Gear	1m44T	1
60	ZX-05732	Small Gear	1m22T	1

Index No.	Part No.	Description	Size	Qty.
61	ZX-05114	Sleeve		1
62	ZX-05734	Lever Shaft		1
63	ZX-05503	Gasket		1
64	ZX-05110-G	Front Cover		1
65	TS-1505021	Hex Socket Cap Screw	M10x20	5
66	ZX-Q66	Taper Pin	5x35	6
67	ZX-05303A	Sign Plate (serial #110930ZX2364 and lower)		1
	ZX-05303B	Sign Plate (serial #160401ZX3031 and lower)		1
	ZX-08301-31	Sign Plate (serial #160410ZX3032 and higher)		1
68	ZX-Q68	Cross Head Screw (serial #160401ZX3031 and lower)	M3x6	7
	GB2672-M3x6	Screw (serial #160410ZX3032 and higher)	M3x6	11
69	ZX-Q69	Oil Sight Glass	20	1
70	ZX-05727	Positioning Disc		1
71	ZX-Q71	Countersunk Head Screw	M4x12	9
72	ZX-05740-G	Lever		1
73	ZX-05130A-G	Lever Support		1
74	ZX-05301	Sign Disc (serial #160401ZX3031 and lower)		2
	C6136ZK-02304-1	Sign Disc (serial #160410ZX3032 and higher)		2
74a	ZX-05301	Sign Disc (serial #160401ZX3031 and lower)		1
	C6136-02306	Sign Disc (serial #160410ZX3032 and higher)		1
75	ZX-H5	Steel Ball	8	3
76	ZX-Q76	Compression Spring	YZ-1x8x25	3
77	ZX-H3	Flat End Set Screw	M10x12	3
78	ZX-05736	Positioning Disc		1
79	ZX-05140-G	Hand Wheel		2
80	ZX-05733	Positioning Disc		1
82	GB70-M8x5	Hex Socket Cap Screw	M8x5	1
83	1440R-05752A-G	Board		1

# Quick Change Gear Box II

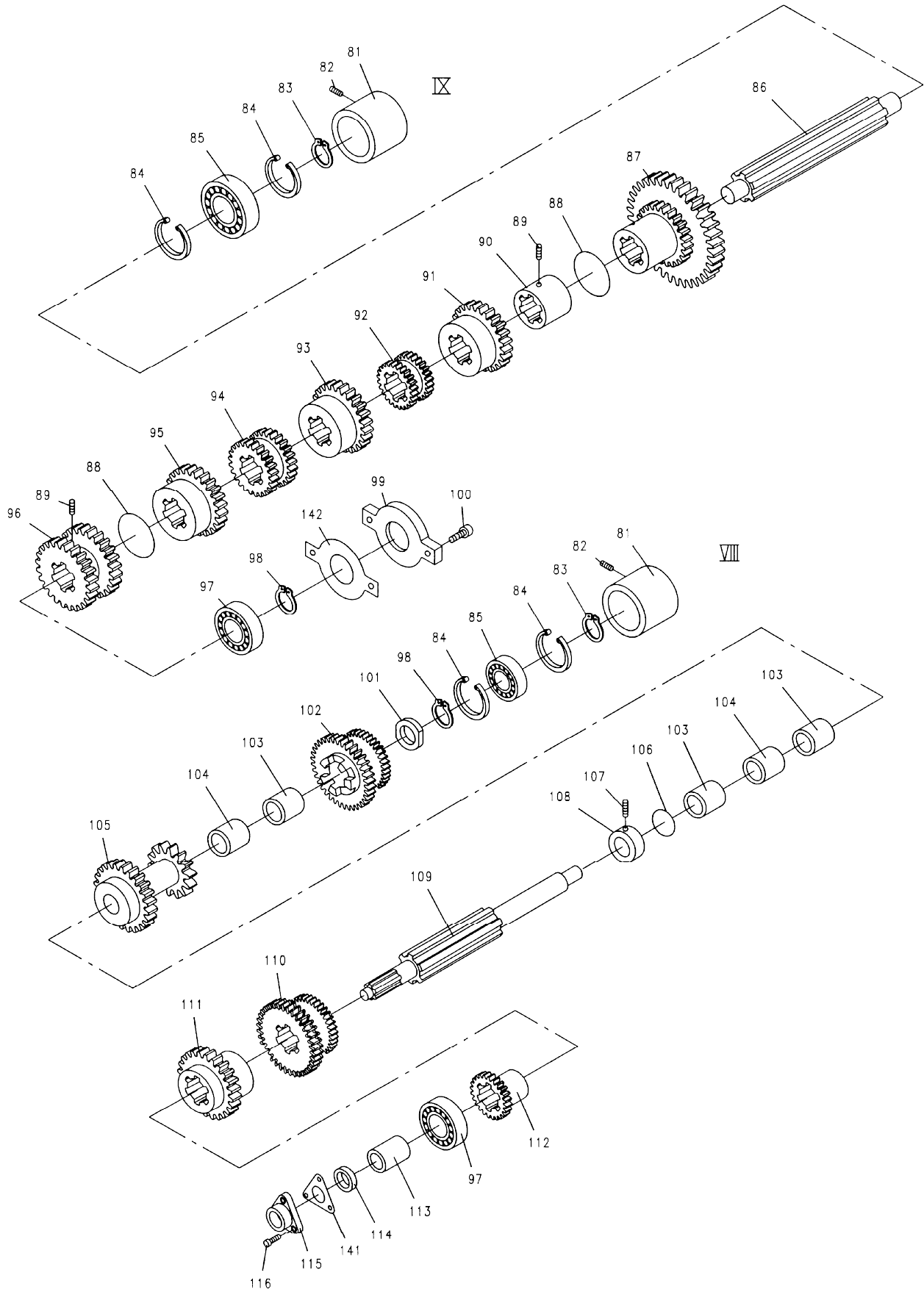

## Quick Change Gear Box II

Index No.	Part No.	Description	Size	Qty.
81	ZX-05104	Middle Bearing Support		2
82	ZX-Q82	Taper End Set Screw	M10x16	2
83	ZX-B23	C-Clip	20	3
84	ZX-Q84	C-Clip	42	5
85	BB-6004	Single Row Radial Ball Bearing	20x42x12	5
86	ZX-05721	Shaft		1
87	ZX-05722	Double Gear	2m26T/2m52T	1
88	ZX-Q88	Iron Wire	1x190	2
89	TS-1524051	Set Screw	M8x20	2
90	ZX-05720	Positioning Sleeve		1
91	ZX-05719	Gear	2.25m28T	1
92	ZX-05718	Double Gear	2m26T/2m28T	1
93	ZX-05717	Gear	3.5m20T	1
94	ZX-05716	Double Gear	3.5m18T/3.5m19T	1
95	ZX-05715	Gear	3.25m22T	1
96	ZX-05714	Double Gear	3.25m24T/3.25m23T	1
97	BB-6205	Single Row Radial Ball Bearing	25x52x15	2
98	ZX-C40	C-Clip	25	3
99	ZX-05125-G	Shaft End Cover		1
100	TS-1504041	Hex Socket Cap Screw	M8x18	2
101	ZX-05704	Spacer		1
102	ZX-05705	Double Gear	2m52T/2m26T	1
103	ZX-05502C	Oil Bushing		3
104	ZX-05105	Sleeve		2
105	ZX-05707	Double Gear	2m39T/2m26T	1
106	ZX-Q106	Iron Wire	1x160	3
107	TS-1524031	Set Screw	M8x12	3
108	ZX-05714C	Fixed Bushing		1
109	ZX-05710	Shaft		1
110	ZX-05709	Double Gear	2m48T/2.25m42T	1
111	ZX-05711	Sliding Gear	3.5m24T	1
112	ZX-05712	Sliding Gear	3.25m24T	1
113	ZX-05713	Sleeve		1
114	ZX-G51-1	Spacer	32	1
115	ZX-05106-G	Bearing Support		1
116	TS-1504051	Hex Socket Cap Screw	M8x25	3
141	ZX-05504	Gasket		1
142	ZX-05505	Gasket		1

# Quick Change Gear Box III

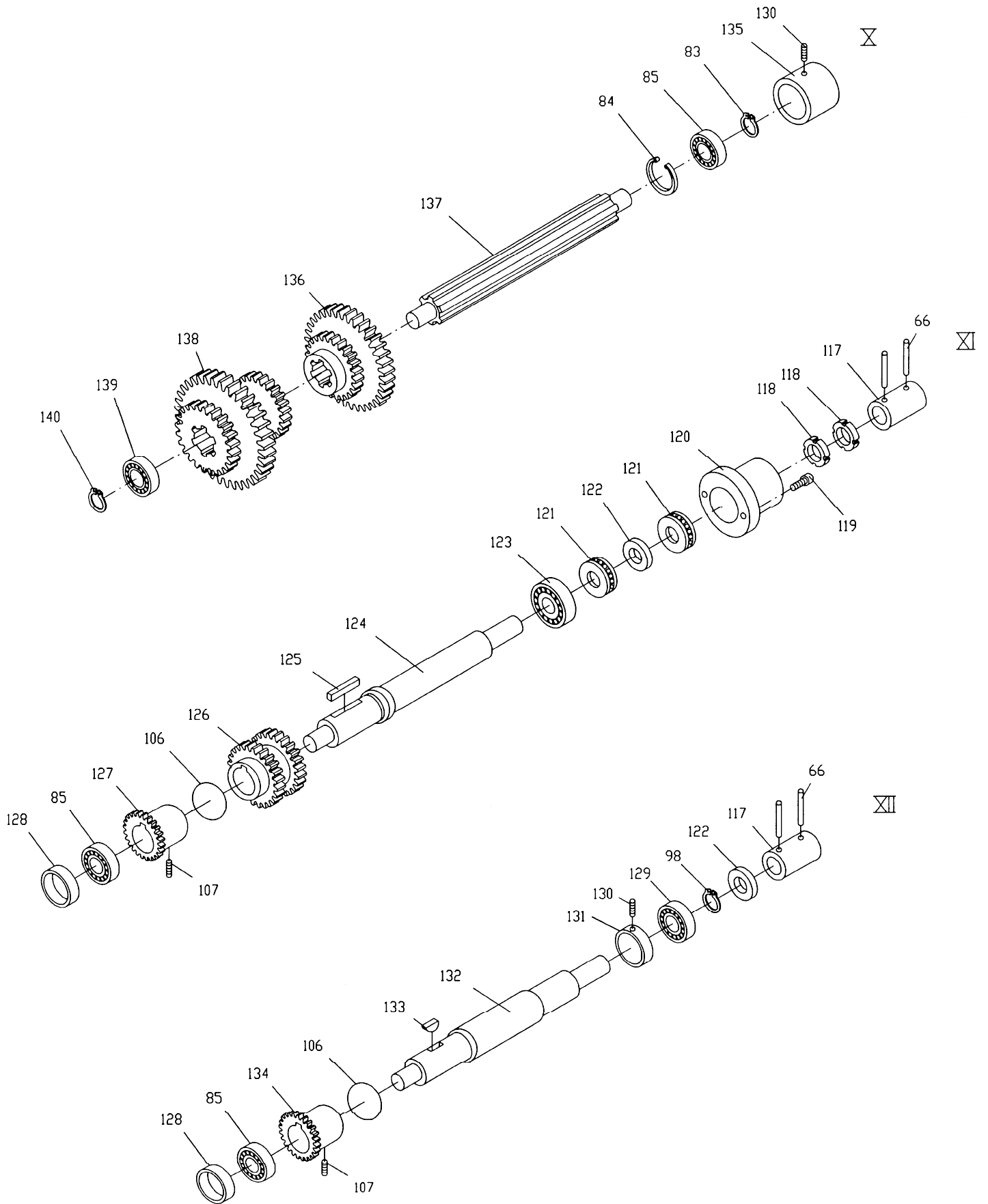

## Quick Change Gear Box III

Index No.	Part No.	Description	Size	Qty.
66	ZX-Q66	Taper Pin	5x35	6
83	ZX-Q83	C-Clip	20	3
84	ZX-Q84	C-Clip	42	5
85	BB104	Single Row Radial Ball Bearing	20x42x12	5
98	ZX-Q98	C-Clip	25	3
106	ZX-Q106	Iron Wire	1x160	3
107	TS-1524031	Set Screw	M8x12	3
117	ZX-05113C	Shaft Coupling		2
118	ZX-Q118	Round Nut	M24x1.5	2
119	TS-1503021	Hex Socket Cap Screw	M6x10	2
120	ZX-05114C-G	Cover		1
121	BB-51105	Thrust Bearing	25x42x11	2
122	ZX-Q122	Spacer	25	2
123	BB-6305	Ball Bearing	25x62x17	1
124	ZX-05725	Shaft		1
125	ZX-Q125	Key	8x7x50	1
126	ZX-05724	Double Gear	2.25m35T/2.25m36T	1
127	ZX-05723	Gear	2.5m36T	1
128	ZX-05107	Sleeve		2
129	BB-6005	Ball Bearing	25x47x12	1
130	TS-1525021	Set Screw	M10x12	2
131	ZX-05103	Bearing Support		1
132	ZX-05701	Shaft		1
133	ZX-Q133	Half Circle Key	6x22	1
134	ZX-05703	Gear	2.5m36T	1
135	ZX-05102	Bearing Support		1
136	ZX-05702	Double Gear	2.5m24T/2.25m35T	1
137	ZX-05708	Shaft		1
138	ZX-05706	Triple Gear	2m39T/2m52T/2m26T	1
139	BB-6203	Ball Bearing	17x40x12	1
140	ZX-Q140	C-Clip	17	1



# Apron Assembly I

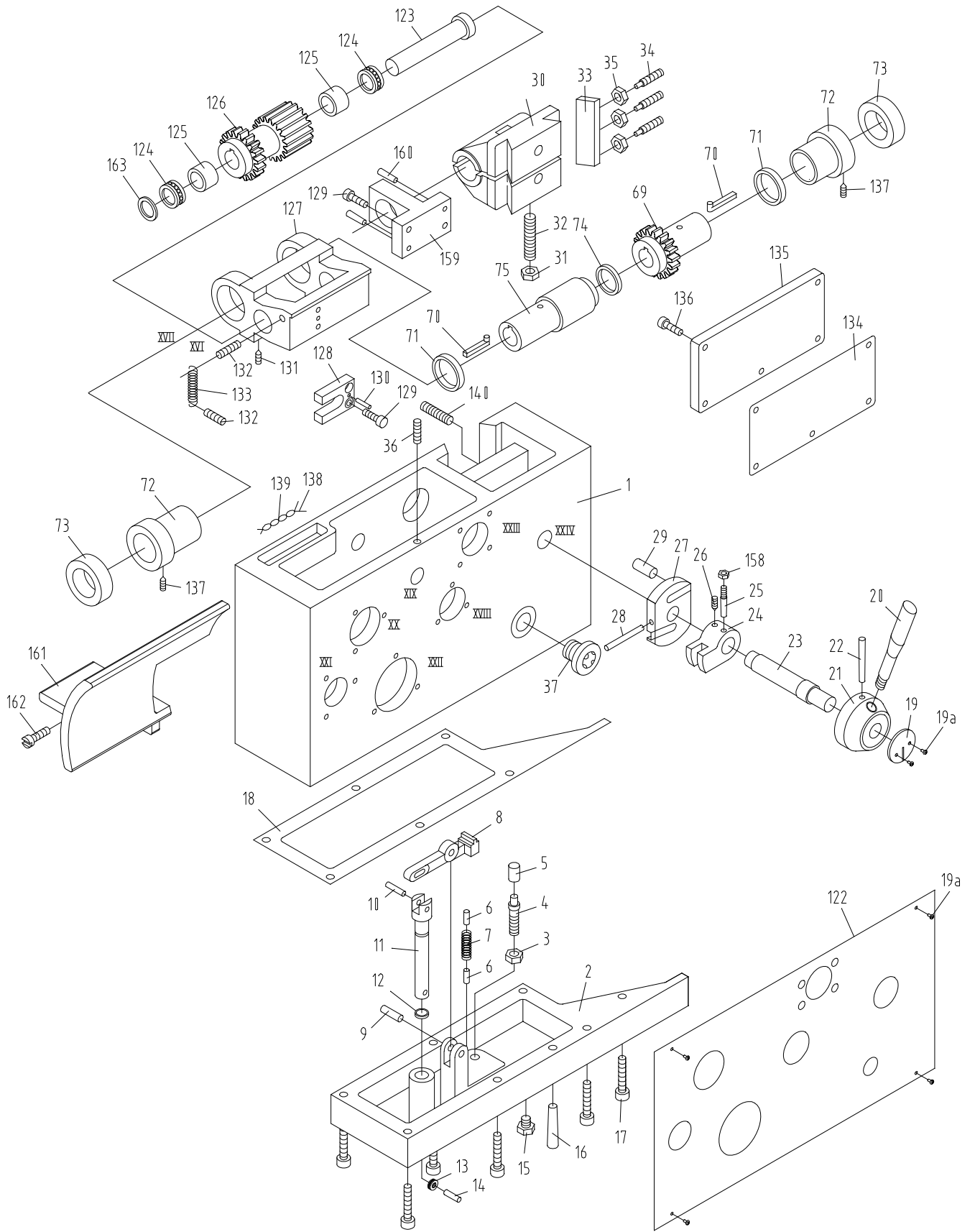

## Apron Assembly I

Index No.	Part No.	Description	Size	Qty.
1	TL06101-G	Apron Casting		1
2	TL06103-G	Bottom Cover		1
3	TS-1540072	Hex Nut	M10	1
4	ZX-A4	Flat Head Set Screw	M10x70	1
5	TL06502	Cushion Cap		1
6	ZX-A6	Pin	6n6x16	2
7	ZX-A7	Tensile Spring	YI1.2x9x50	1
8	TL06734	Lever		1
9	ZX-A9	Pin	8n6x30	1
10	ZX-A10	Pin	6n6x18	1
11	TL06701-A	Pushing Rod		1
12	ZX-A12	Oil Seal	15x2.4	1
13	BB60016	Ball Bearing	6x17x6	1
14	ZX-A6	Pin	6n6x16	1
15	GB70	Hex Socket Cap Screw	M8×6	1
16	ZX-B34	Taper Pin	5x30	2
17	TS-1504041	Hex Socket Cap Screw	M8x20	6
18	TL06501	Gasket		1
19	TL06307	Sign Plate (serial #160401ZX3031 and lower)		1
	C0632B05302-2	Sign Plate (serial #160410ZX3032 and higher)		1
19a	GB2672- M3x6	Screw (serial #160410ZX3032 and higher)	M3x6	6
20	TL06716-G	Lever		1
21	ZX-06122-G	Lever Support		1
22	ZX-B27	Taper Pin	6x60	1
23	TL06717	Half Nut Shaft		1
24	TL06111	Positioning Block		1
25	ZX-A25	Thread Tail Taper Pin	6x25	1
26	TS-1523031	Set Screw	M6x10	1
27	ZX-06733	Half Nut Control Plate		1
28	ZX-A28	Taper Pin	6x55	1
29	ZX-06732	Pin		2
30	ZX-06302	Half Nut (serial # 010611ZX349 and lower)		1
	ZX-06302N	New Half Nut (serial # 010618ZX350 and higher)		1
31	TS-1540072	Hex Nut	M10	1
32	ZX-A32	Cylindrical End Set Screw	M10x60	1
33	ZX-06121	Gib		1
34	ZX-06731	Cylindrical End Set Screw		3
35	TS-1540061	Hex Nut	M8	3
36	ZX-A36	Set Screw	M8x32	1
37	ZX-A37	Oil Sight Glass	20	1
69	TL06727	Gear (serial # 010611ZX349 and lower)	2m25T	1
	TL06727N	New Gear (serial # 010618ZX350 and higher)	2m25T	1
70	TL06728	Sliding Key		2
71	TL06121	Spacer (serial # 010611ZX349 and lower)		2
	TL06121N	New Spacer (serial # 010618ZX350 and higher)		2
72	TL06304	Positioning Sleeve (serial # 010611ZX349 and lower)		2
	TL06304N	New Positioning Sleeve (serial # 010618ZX350 and higher)		2
73	ZX-A73	Ring Seal For Rotating	3x55	2
74	ZX-A74	Oil Seal	35x3.1	1
75	TL06729	Sleeve (serial # 010611ZX349 and lower)		1
	TL06729N	New Sleeve (serial # 010618ZX350 and higher)		1
122	TL06302	Sign Plate (serial #160401ZX3031 and lower)		1
	TL06302B-10	Sign Plate (serial # 160410ZX3032 and higher)		1
123	TL06730	Shaft		1
124	BB-51104	Thrust Bearing		2
125	TL06305	Sleeve		2

Index No.	Part No.	Description	Size	Qty.
126	TL06726	Worm (serial # 010611ZX349 and lower)		1
	TL06726N	New Worm (serial # 010618ZX350 and higher)		1
127	TL06122	Worm Support (serial # 010611ZX349 and lower)		1
	TL06122N	New Worm Support (serial # 010618ZX350 and higher)		1
128	TL06720	Control Plate		1
129	TS-1514031	Hex Socket Cap Screw	M6x20	4
130	ZX-A130	Taper Pin	4x20	1
131	TS-1524031	Set Screw	M8x12	2
132	ZX-A132	Screw	M8x25	2
133	ZX-A133	Cylindrical Tensile Spring	LI-1.6x10x58	1
134	TL06503	Gasket		1
135	TL06114-G	Back Cover		1
136	TS-1514011	Hex Socket Cap Screw	M6x12	5
137	ZX-A137	Set Screw	M8x30	2
138	ZX-A138	Iron Wire	1x50	2
139	ZX-A139	Oil Conducting Cord	3x100	2
140	ZX-A140	Screw	M10x40	1
158	TS-1540041	Hex Nut	M6	1
159	TL06124	Bracket		1
160	ZX-A160	Taper Pin	5x25	2
161	TL06308-G	Bracket		1
162	TS-1503041	Hex Socket Cap Screw	M6x16	1
163	TL06120	Sleeve		1

# Apron Assembly II

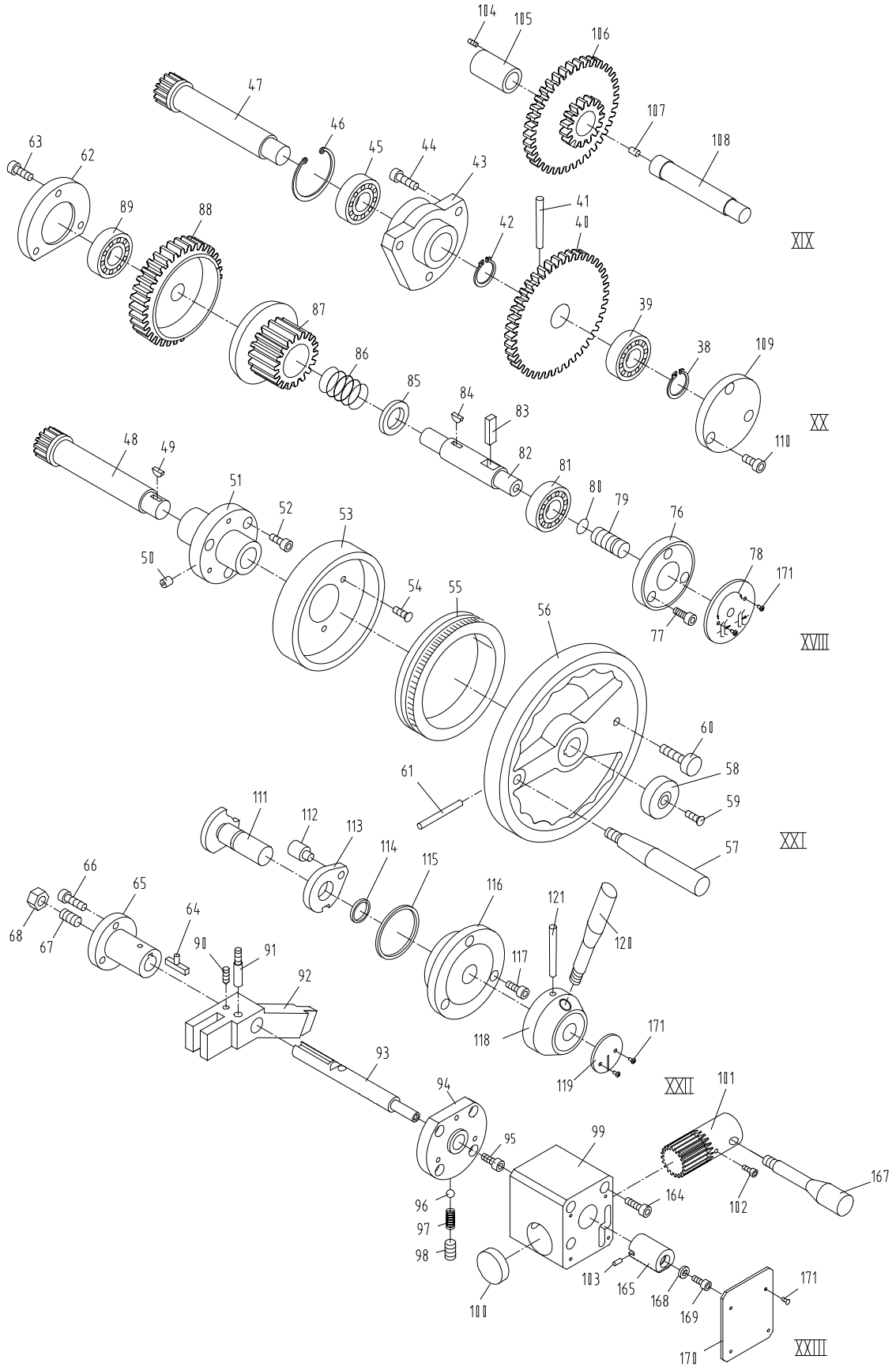

## Apron Assembly II

Index No.	Part No.	Description	Size	Qty.
38	ZXB23	C-Clip	20	1
39	BB6204	Ball Bearing	20x47x14	1
40	TL06705	Gear	2m65T	1
41	ZXA41	Taper Pin (serial #121220ZX2630 and lower)	6x40	1
	GB877- 6x45	Taper Pin (serial #130102ZX2631 and higher)	6x45	1
42	ZXC40	C-Clip	25	1
43	ZX06127N	New Bearing Support		1
44	TS1504041	Hex Socket Cap Screw	M8x18	3
45	BB6205Z	Ball Bearing	25x52x15	1
46	ZXA46	C-Clip	52	1
47	TL06704N	New Shaft	2m14T	1
48	TL06706	Hand Wheel Shaft	2mx15T	1
49	ZXH10	Half Circle Key	4x16	1
50	ZXA50	Oil Cup	8	1
51	TL06104	Lever Support		1
52	TS1514031	Hex Socket Cap Screw	M6x18	3
53	TL06105 (in)	Dial Support		1
54	ZXA54	Cross Head Screw	M5x12	3
55	TL06732 (in)	Dial		1
56	TL06107-G	Hand Wheel		1
57	ZX06710-G	Shaft Driven Lever		1
58	TL06709	Shaft Cover		1
59	ZXA54	Cross Head Screw	M5x12	1
60	TL06708	Screw		1
61	TL06707	Pin		1
62	TL06112	End Cover		1
63	TS1514011	Hex Socket Cap Screw	M6x12	3
64	TL06733	T Shaped Flat Key		1
65	TL06115	Flange Sleeve		1
66	TS1514011	Hex Socket Cap Screw	M6x12	3
67	ZXA67	Flat End Set Screw	M6x30	1
68	TS1540041	Hex Nut	M6	1
76	TL06109-G	Flange		1
77	TS1514011	Hex Socket Cap Screw	M6x12	3
78	TL06303	Sign Plate (serial #160401ZX3031 and lower)		1
	TL06303-1	Sign Plate (serial #160410ZX3032 and higher)		1
79	TL06714	Adjusting Screw		1
80	ZXA80	Oil Seal	8x1.9	1
81	BB7203	Ball Bearing	17x40x12	1
82	TL06713	Shaft		1
83	TL06715	Adjusting Rod		1
84	ZXH10	Half Circle Key	4x16	1
85	TL06712	Spring Cover		1
86	ZXA86	Spring	YI-4x32x40	1
87	TL06718	Gear	2m28T	1
88	TL06113	Helical Gear	2.5m40T	1
89	BB7006/P6	Ball Bearing	30x55x13	1
90	TS1523031	Set Screw	M6x10	1
91	ZXA25	Thread Tail Taper Pin	6x25	1
92	TL06110	Fork		1
93	ZX06721E	Control Rod (serial #120520ZX2472 and higher)		1
94	ZX06116E-G	Lever Support (serial #120520ZX2472 and higher)		1
95	ZXA95E	Cross Head Screw (serial #120520ZX2472 and higher)	M6x30	1
96	ZXH5	Steel ball (serial #120520ZX2472 and higher)	8	1
97	ZXA97	Spring (serial #120520ZX2472 and higher)	YI-1x7x25	1

Index No.	Part No.	Description	Size	Qty.
98	ZXA98	Flat Head Set Screw (serial #120520ZX2472 and higher)	M10x16	1
99	ZX06737E	Bracket (serial #120520ZX2472 and higher)		1
100	ZX06741E	Plug (serial #120520ZX2472 and higher)		1
101	ZX06739E-G	Gear shaft (serial #120520ZX2472 and higher)		1
102	ZXA102E	Hex head screw (serial #120520ZX2472 and higher)	M4x8	1
103	ZXA103E	Pin (serial #120520ZX2472 and higher)	4x8	1
104	ZXA104	Flat Head Set Screw	M4x8	1
105	TL06301	Sleeve		1
106	TL06710	Gear	2m21T/2m57T	1
107	ZXA107	Pin	6n6x8	1
108	TL06711	Shaft		1
109	TL06108-G	End Cover		1
110	TS1514011	Hex Socket Cap Screw	M6x12	3
111	TL06723	Control Shaft		1
112	TL06725	Pin		1
113	TL06724	Control Block		1
114	ZXA114	Oil Seal	20x2.4	1
115	ZXA115	Oil Seal	50x3.1	1
116	TL06119	Lever Flange		1
117	TS1514011	Hex Socket Cap Screw	M6x12	3
118	TL06118	Lever Support (serial #120520ZX2472 and lower)		1
	TL06118-G	Lever Support		1
119	TL06307	Sign Plate (serial #160401ZX3031 and lower)		1
	C0632B05302-2	Sign Plate (serial #160410ZX3032 and higher)		1
120	ZXK06722	Lever (serial #120520ZX2472 and lower)		1
	ZXK06722-G	Lever		1
121	ZXB27	Taper Pin	6x60	1
164	ZXA164E	Hex head screw (serial #120520ZX2472 and higher)	M6x35	3
165	ZX06738E	Rack (serial #120520ZX2472 and higher)		1
167	ZX06740E	Handle (serial #120520ZX2472 and lower)		1
	ZX06740E-G	Handle		1
168	ZX06736E	Washer (serial #120520ZX2472 and higher)		1
169	ZXA169E	Hex head screw (serial #120520ZX2472 and higher)	M5x10	1
170	ZX06303E	Label (serial #160401ZX3031 and lower)		1
	ZX06303-2	Label (serial #160410ZX3032 and higher)		1
171	ZXA171E	Screw (serial #160401ZX3031 and lower)	M3x5	4
	GB2672- M3x6	Screw (serial #160410ZX3032 and higher)	M3x6	8

### Apron Assembly III

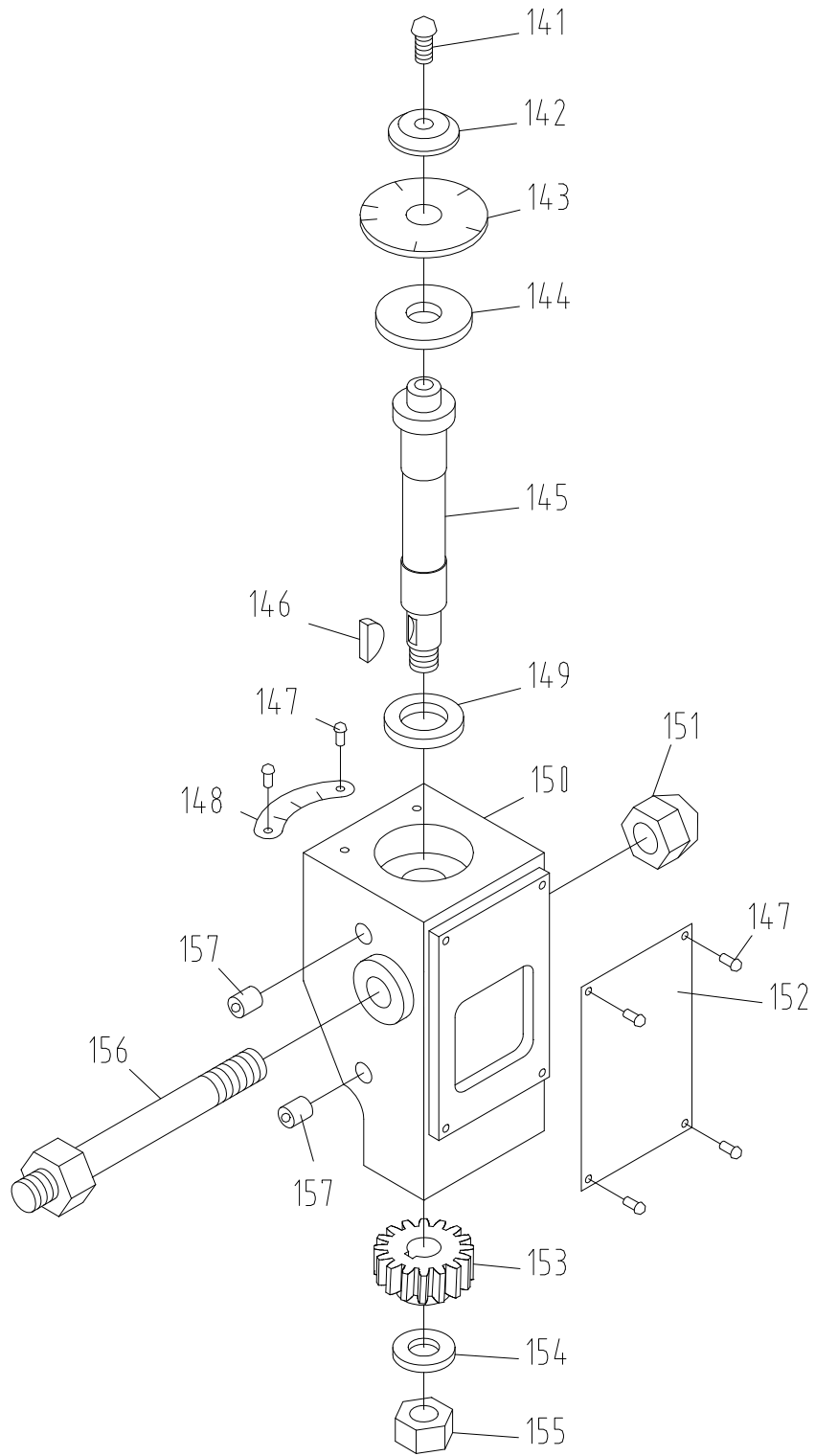

### Apron Assembly III

Index No.	Part No.	Description	Size	Qty.
141	ZX-A141	Half Round Head Screw	M6x18	1
142	ZX-11704	Washer		1
143	ZX-11301	Dial (serial #160401ZX3031 and lower)		1
	ZX-11302-2	Dial (serial #160410ZX3032 and higher)		1
144	ZX-11105	Adjusting Washer		1
145	ZX-11701	Shaft		1
146	ZX-H10	Half Circle Key	4x16	1
147	ZX-A147	Half Round Head Screw (serial #160401ZX3031 and lower)	M3x6	6
	GB2672-M3x6	Screw (serial #160410ZX3032 and higher)	M3x6	6
148	ZX-11303	Positioning Sign Plate		1
149	ZX-11703	Adjusting Washer		1
150	ZX-11101-G	Casting		1
151	ZX-A151	Acorn Nut	M12	1
152	ZX-11304	Thread Chasing Label (serial #160401ZX3031 and lower)		1
	ZX-11304-1	Thread Chasing Label (serial #160410ZX3032 and higher)		1
153	ZX-11102	Helical Gear	2m16T	1
154	TS-1550071	Flat Washer	M10	1
155	TS-1540072	Hex Nut	M10	1
156	ZX-11702	Bolt		1
157	ZX-A157	Oil Cup	8	2



# Carriage Assembly

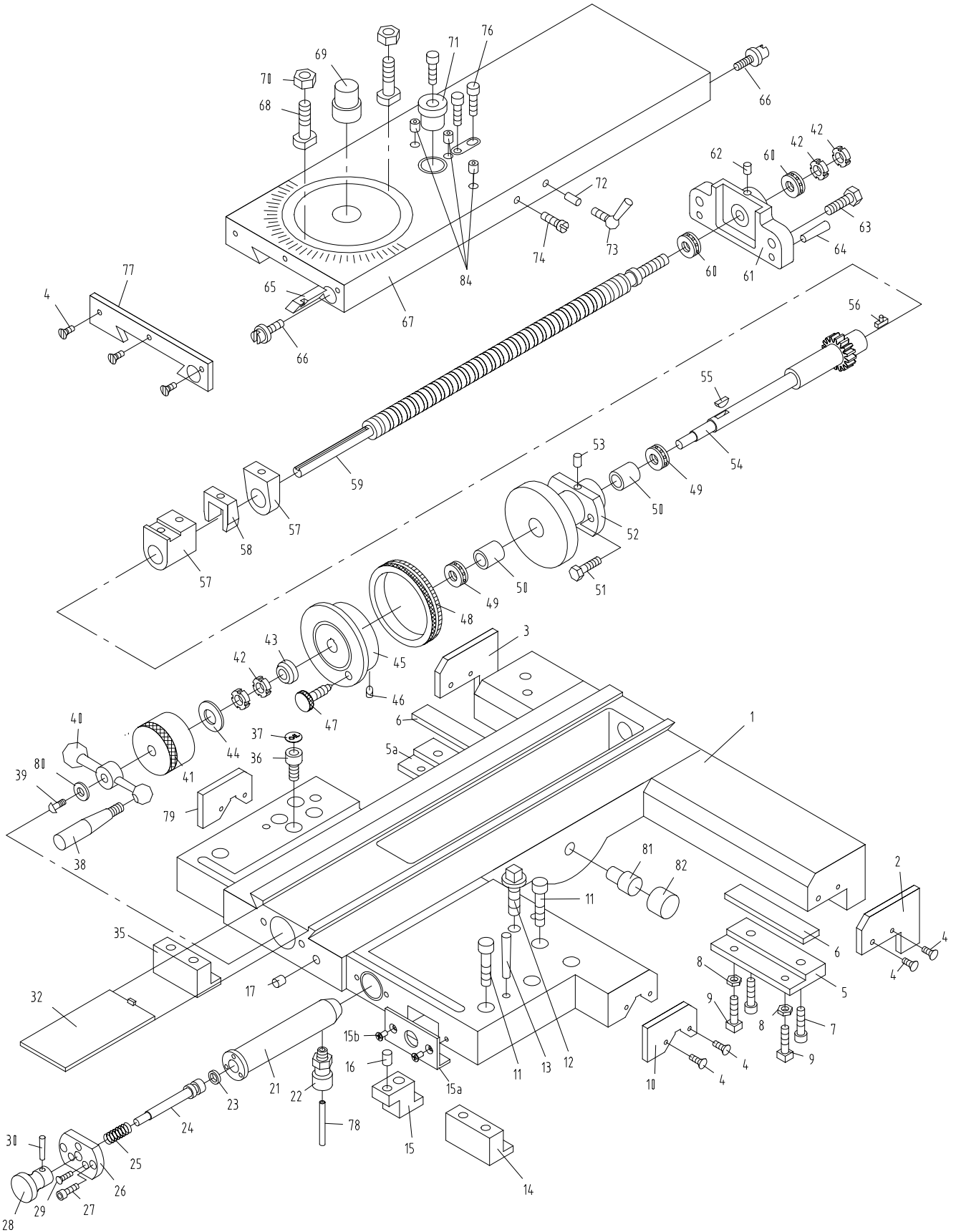

## Carriage Assembly

Index No.	Part No.	Description	Size	Qty.
1	ZX K04101A	Saddle Casting (for 14" / 16" / 18" models)		1
	ZX K04101B	Saddle Casting (for 14" / 16" / 18" models) (serial #160410ZX3032 and higher)		1
	GH-2280ZX K04101A	Saddle Casting (for 22" models)		1
	GH-2280ZX K04101B	Saddle Casting (for 22" models) (serial #160410ZX3032 and higher)		1
2	ZX04505	Wipe Plate (serial #100308ZX2172 and lower)		1
	ZX04505J	Wipe Plate (serial #100329ZX2173 and higher)		1
3	ZX04504	Wipe Plate (serial #100308ZX2172 and lower)		1
	ZX04504J	Wipe Plate (serial #100329ZX2173 and higher)		1
4	ZXH211	Countersunk Head Screw (serial #100308ZX2172 and lower)	M5x16	11
	ZXC04	Half Round Head Screw (serial #100329ZX2173 and higher)	M5x16	11
5	ZX-04724	Clamping Block		1
5a	ZX-04724	Clamping Block (serial #160401ZX3031 and lower)		1
	1440R04724A	Clamping Block (serial #160410ZX3032 and higher)		1
6	ZX-04113	Lining Plate		2
7	TS-1505041	Hex Socket Cap Screw	M10x30	4
8	TS-1540061	Hex Nut	M8	4
9	ZX-CA09	Square Set Screw	M8x20	4
10	ZX04506	Wipe Plate (serial #100308ZX2172 and lower)		1
	ZX04506J	Wipe Plate (serial #100329ZX2173 and higher)		1
11	TS-1505071	Hex Socket Cap Screw	M10x45	8
12	ZX-CA12	Square Cap Bolt	M12x70	1
13	ZX-CA13	Taper Pin	8x60	2
14	ZX-04729	Clamping Block		1
15	ZX-04730	Locking Plate		1
15a	20151026	Button Support (serial #160410ZX3032 and higher)		1
15b	GB819-M6x12	Countersunk Head Screw (serial #160410ZX3032 and higher)	M6x12	2
16	ZX-CA16	Pin	4n6x12	1
17	ZX-04772	Blocking Piece		1
21	ZX-04782	Manual Oil Pump Casting		1
22	ZX-04781A	In Valve		1
23	ZX-CA23	Oil Ring	15x2.4	1
24	ZX-04784	Piston		1
25	ZX-CA25	Spring	1.2x14x65	1
26	ZX-04785-G	Oil Pump Cover		1
27	TS-1502041	Hex Socket Cap Screw	M5x16	2
28	ZX-04783-G	Lever		1
29	ZX-CA29	Countersunk Head Screw	M4x16	3
30	ZX-A130	Taper Pin	4x20	1
32	ZX-04716	Chip Guard		1
35	ZX-04740	Clamping Block		1
36	ZX-04750	Oil Cap		1
37	ZX-04301-G	Oil Indicator Cap Plate		1
38	ZX-04721-G	Lever		1
39	ZX-CA39	Cross Head Screw	M5x16	1
40	ZX-04720-G	Handle		1
41	ZX-04769-G	Sleeve		1
42	ZX-CA42	Round Nut	M12x1.25	4
43	ZX-04719	Lining		1
44	ZX-04770	Disc Spring		1
45	ZX-04108-G	Flat Pan		1
46	ZX-04790	Pushing Rod		1

Index No.	Part No.	Description	Size	Qty.
47	ZX-04789	Screw		1
48	ZX-04717	Dial		1
49	BB-51102	Thrust Bearing	15x28x9	2
50	ZX-04111	Sleeve		2
51	TS-1490041	Hex Cap Bolt	M8x25	2
52	ZX-04109	Screw Support		1
	GH2280ZX-04109B	Screw Support (for 2280ZX)		1
53	ZX-CA53	Oil Cup	8	1
54	ZX-04707-1	Gear Sliding Sleeve	2m16T	1
	GH2280ZX-04707-1	Gear Sliding Sleeve(for 2280ZX)		1
55	ZX-H10	Half Circle Key	4x16	1
56	ZX-04751	Flat Key		1
57	ZX-04302	Nut Assembly		1
	ML-2080-04301	Nut Assembly (for 2280ZX)		1
58	ZX-04748	Wedge		1
59	ZX-04707-2	Lead Screw		1
	GH2280ZX-04707-2	Lead Screw (for 2280ZX)		1
60	BB-51101/P6	Thrust Bearing	12x26x9	2
61	ZX-04116-G	Bracket		1
62	ZX-CA62	Oil Cup	6	1
63	TS-1491041	Cap Screw	M10x30	2
64	ZX-CA64	Taper Pin	8x30	2
65	ZX-04731	Cross Slide Gib		1
66	ZX-04725C	Screw		2
67	ZX-04102A	Cross Slide		1
	GH2280ZX-04102	Cross Slide (for 2280ZX)		1
68	ZX-04714	Screw (for 18"/22" models, T-Slot)		2
	ZX-04714C	Screw (for 14"/16" models, T-Slot)		2
69	ZX-04732	Pin		1
70	TS-1540081	Hex Nut	M12	2
71	ZX-04709	Sleeve		1
	GH2280ZX-04701	Sleeve (for 2280ZX)		1
72	ZX-04304	Pressing Pin		1
73	ZX-04746-G	Screw		1
74	ZX-04786-G	Set Screw		1
76	TS-1504051	Socket Head Cap Screw	M8x22	3
77	ZX-04502	Wipe Plate (serial #100308ZX2172 and lower)		1
	GH2280ZX-04502	Wipe Plate (for 2280ZX) (serial # 100308ZX2172 and lower)		1
	ZX-04502J	Wipe Plate (serial #100329ZX2173 and higher)		1
	GH2280ZX-04502J	Wipe Plate (for 2280ZX) (serial #100329ZX2173 and higher)		1
78	ZX-CA78	Copper Tube		6
79	ZX04503	Wipe Plate (serial #100308ZX2172 and lower)		1
	ZX04503J	Wipe Plate (serial #100329ZX2173 and higher)		1
80	ZX-04771-G	Lining		1
81	ZX-04788	Stop Pin		1
82	ZX-04507	Stop Pin Cap		1
84	ZX-CA84	Oil Cup	10	3
85	ZXCA85	Turcite-B (not shown)	550x50x0.8	1
86	ZXCA86	Turcite-B (not shown)	550x25x0.8	2
	ZX-CSNA	Crossfeed Screw & Nut Assy. (includes # 57- 59. for 14/16/18")		
	ZX-CSNA-GH2280ZX	Crossfeed Screw & Nut Assy. (includes #57-59,. for 22")		
	ZX-CDA	Crossfeed Dial Assy. (includes # 41-50, 51-56. for 14/16/18")		
	ZX-CDA-GH2280ZX	Crossfeed Dial Assy. (includes # 41-50, 51-56. for 22")		

## Micro Carriage Stop

Index No.	Part No.	Description	Size	Qty.
1	ZX-09709	Dial		1
2	ZX-MS2	Pin	B4x8	1
3	ZX-09708	Axle		1
4	ZX-09105-G	Stop		1
5	ZX-03302	Sign Plate		1
6	ZX-MS6	Nail	3x8	2
7	ZX-MS7	Hex Socket Set Screw	M6x12	1
8	ZX-09106	Clamping Plate		1
9	ZX-MS9	Hex Socket Cap Screw	M8x20	2

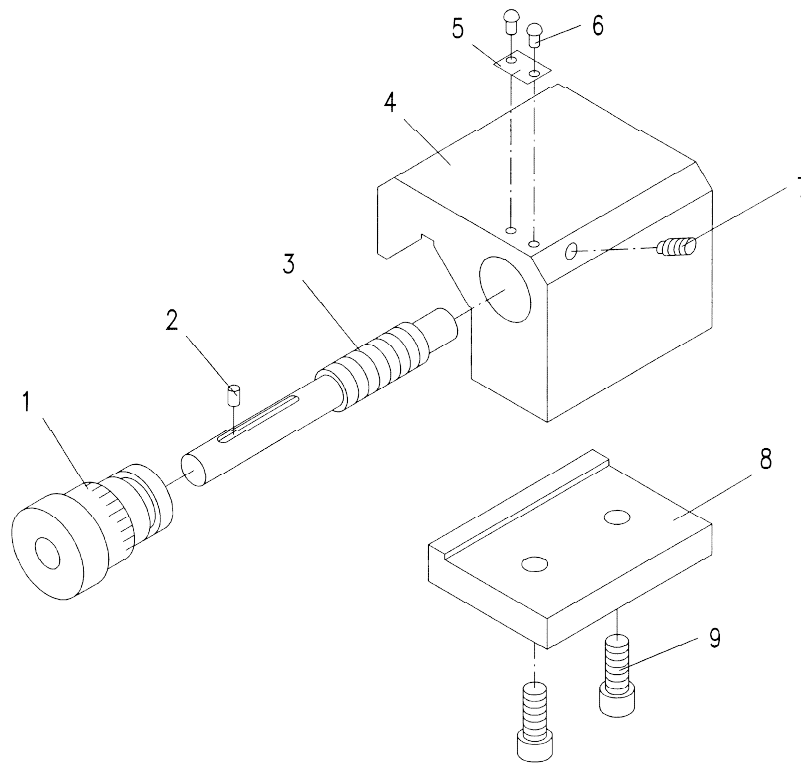

# Carriage Stop Assembly

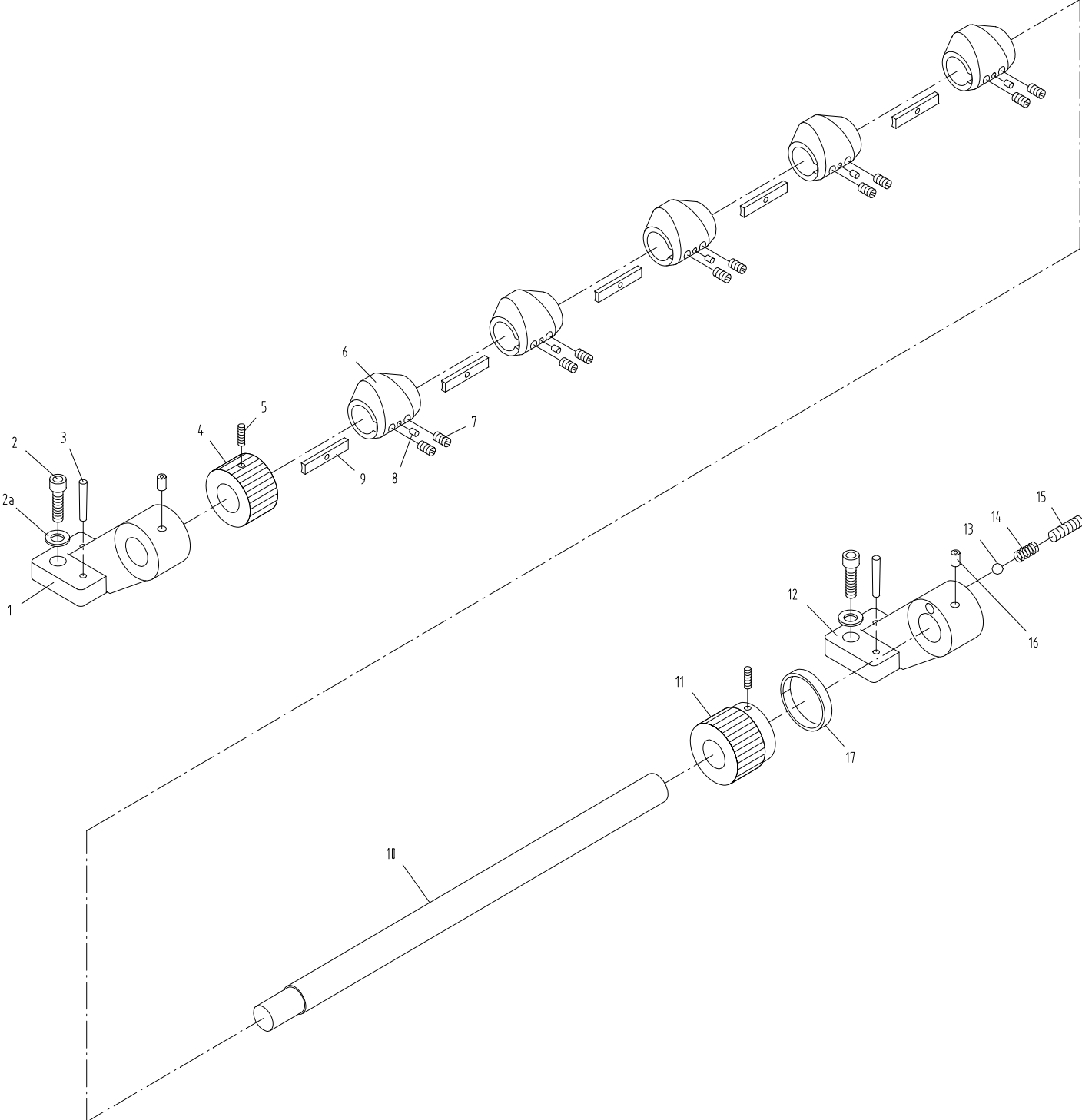

## Carriage Stop Assembly

Index No.	Part No.	Description	Size	Qty.
1	ZX-26101-G	Left Support		1
2	TS-1504041	Hex Socket Cap Screw	M8x20	4
2a	GB5287-8	Thick Washer	8	4
3	ZX-C34	Taper Pin	6x30	4
4	ZX-26704-G	Control Ring		1
5	TS-1523031	Set Screw	M6x10	2
6	ZX-26702	Eccentric Travel Setting Ring		5
7	ZX-H66	Flat End Set Screw	M6x10	10
8	ZX-C08	Pin	4n6x10	5
9	ZX-26703	Locking Key		5
10	ZX-26701A	Travel Setting Rod (for 1440/1640/1840ZX)		1
	ZX-26701B	Travel Setting Rod (for 1460/1660/1860ZX)		1
	ZX-26701C	Travel Setting Rod (for 1880/2280ZX)		1
11	ZX-26705-G	Control Ring		1
12	ZX-26104-G	Right Support		1
13	ZX-H5	Steel Ball	8	1
14	ZX-CS14	Compression Spring	2x8x25	1
15	ZX-CS15	Flat Head Set Screw	M10x12	1
16	ZX-CS16	Oil Cup	8	2
17	ZX-26301	Dial		1

# Quick Change Tool Post

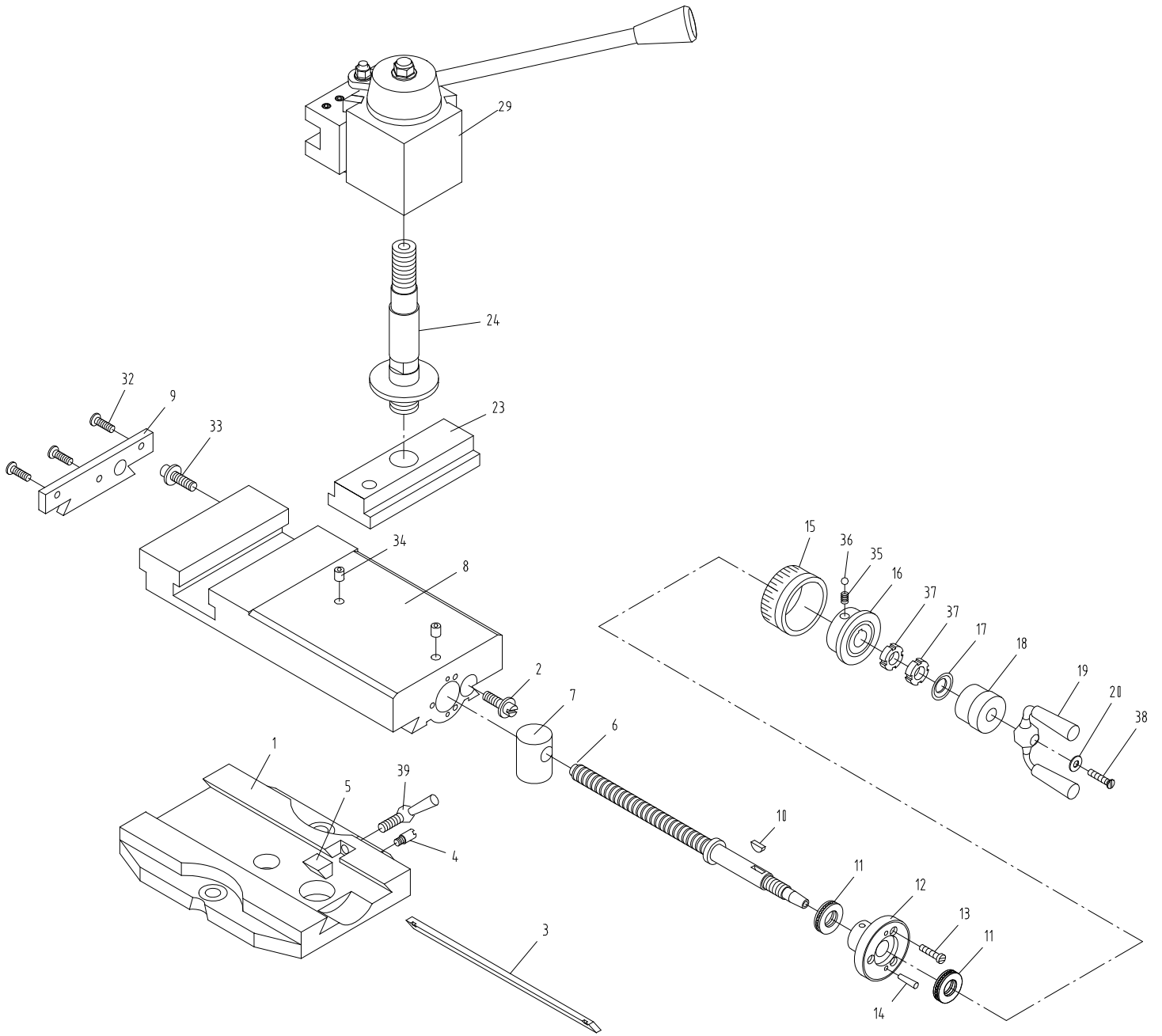

## Quick Change Tool Post

Index No.	Part No.	Description	Size	Qty.
1	ZX-04103A	Revolving Plate (for 14" models)		1
	ZX-04103B	Revolving Plate (for 16" models)		1
	ZX-04103C	Revolving Plate (for 18" models)		1
	GH2280ZX-04103	Revolving Plate (for 22" model)		1
2	ZX-04725	Screw		1
3	ZX-04710	Gib		1
4	ZX-04786-G	Screw		1
5	ZX-04303	Pressing Block		1
6	ZX-04706	Lead Screw		1
7	ZX-04106A	Nut		1
8	ZX-04107A	Top Slide (for 14" models)		1
	ZX-04107B	Top Slide (for 16"/18" models)		1
	GH2280ZX-04107	Top Slide (for 22" model)		1
9	ZX-04501	Wipe Plate		1
10	ZX-F10	Half Circle Key	3x13	1
11	BB-51102	Thrust Bearing	15x28x9	2
12	ZX-04115	Sleeve		1
13	ZX-F13	Slotted Cheese Head Screw	M5x12	3
14	ZX-F14	Taper Pin	3x18	2
15	ZX-04727	Dial		1
16	ZX-04114	Sleeve		1
17	ZX-04768	Disc Spring		1
18	ZX-04767-G	Sleeve		1
19	ZX-04726-G	Handle		1
20	ZX-04771-G	Lining		1
23	ZX-04752A	T-Slot Nut		1
24	ZX-04754	Shaft(serial #160401ZX3031 and lower)		1
	1840ZX04801KH	Shaft(serial #160410ZX3032 and higher)		1
29	ZX-04713A	Tool Post (for 14"models) (serial #160401ZX3031 and lower)		1
	ZX-04713B	Tool Post (for 16"/18"/22" models) (serial #160401ZX3031 and lower)		1
	251-444	Quick Change Tool Post(serial #160410ZX3032 and higher)		1
32	ZX-H211	Countersunk Head Screw	M5x16	3
33	ZX-04725C	Screw		1
34	ZX-F34	Oil Cup	8	2
35	ZX-F35	Spring	0.7x5x9	2
36	ZX-F36	Steel Ball	6	2
37	ZX-F37	Round Nut	M12x1.25	2
38	ZX-CA39	Cross Head Screw	M5x16	1
39	ZX-04746K-G	Screw Wrench		1
	ZX-CPA14-G	Compound Assembly 14" (includes # 1-20,32-39)		
	ZX-CPA16-G	Compound Assembly 16" (includes # 1-20,32-39)		
	ZX-CPA18-G	Compound Assembly 18" (includes # 1-20,32-39)		
	ZX-CPA22-G	Compound Assembly 22" (includes # 1-20,32-39)		



# Tailstock Assembly I

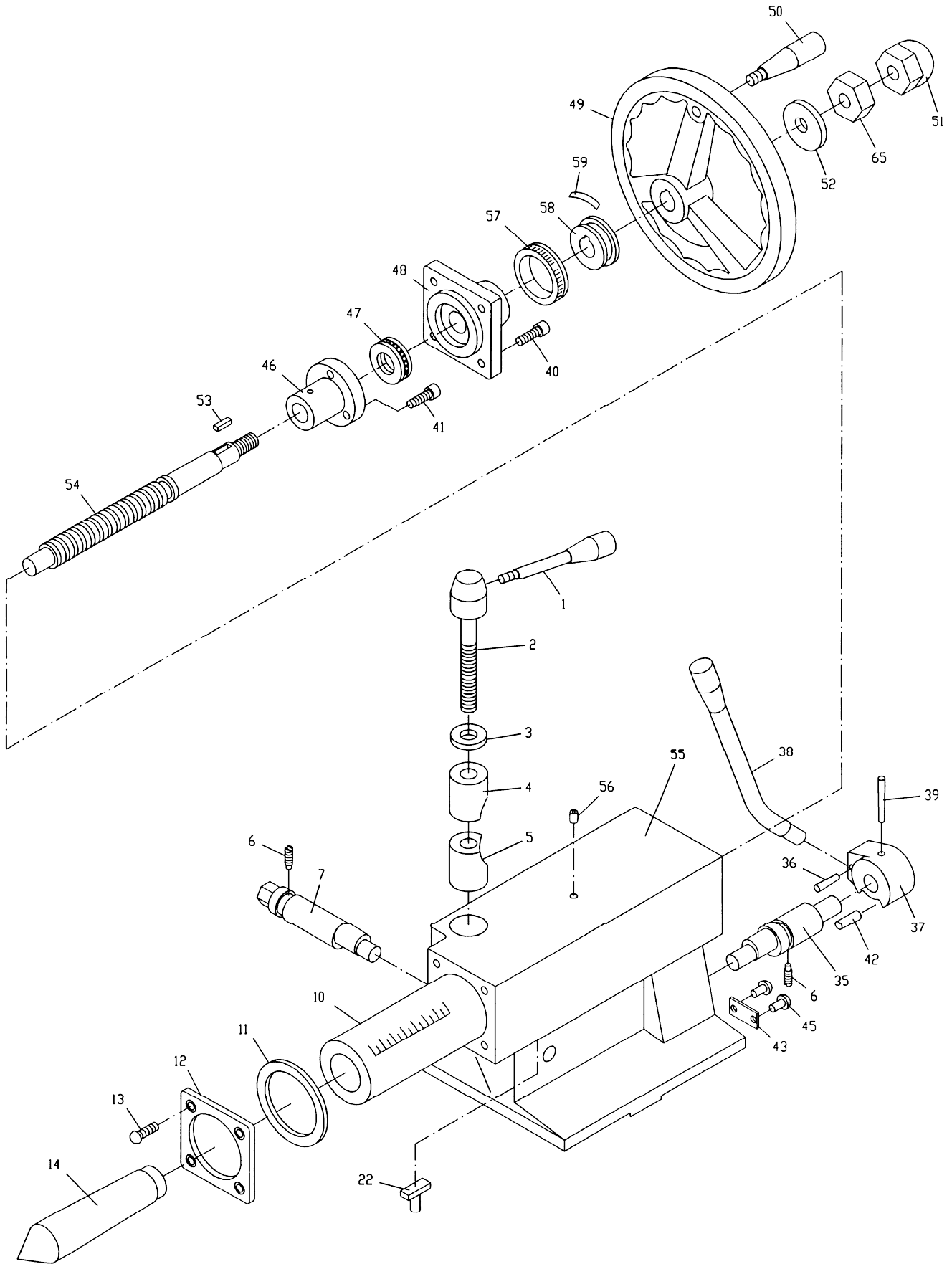

## Tailstock Assembly I

Index No.	Part No.	Description	Size	Qty.
1	ZX-03711-G	Handle		1
2	ZX-03717-G	Lever Support		1
3	ZX-03718	Washer		1
4	ZX-03719	Clamping Block		1
5	ZX-03720	Clamping Block		1
6	ZX-T06	Cylindrical End Set Screw	M8x14	2
7	ZX-03712	Eccentric Shaft		1
10	ZX-03701A	Center Sleeve (for 18"/22" models)		1
	ZX-03701B	Center Sleeve (for 14"/16" models)		1
11	ZX-T11	Ring Seal	75x2.65	1
12	ZX-03703	Front Cover		1
13	ZX-T13	Cross Recessed Countersunk Head Screw	M5x10	4
14	ZX-T14A	Center Morse (for 18"/22" models)	No.5	1
	ZX-T14B	Center Morse (for 14"/16" models)	No.4	1
22	ZX-03702	Positioning Block		1
35	ZX-03714	Eccentric Shaft		1
36	ZX-T36	Taper Pin	6x32	1
37	ZX-03104-G	Lever Sleeve		1
38	ZX-03709-G	Lock handle		1
39	ZX-A28	Taper Pin	6x55	1
40	TS-1504041	Hex Socket Cap Screw	M8x20	4
41	TS-1515031	Hex Socket Cap Screw	M8x22	3
42	ZX-T42	Pin	10n6x22	1
43	ZX-03302	Sign Plate		1
45	ZX-T45	Nail	3x8	4
46	ZX-03105	Nut		1
47	BB-51205	Thrust Ball Bearing	25x47x15	1
48	ZX-03104	Back Cover		1
49	ZX-03103A-G	Hand Wheel		1
50	ZX-03707-G	Lever		1
51	ZX-T51	Acorn Nut	M16	1
52	TS-155010	Flat Washer	M16	1
53	ZX-T53	Key	6x40	1
54	ZX-03710A	Lead Screw (for 18"/22" models)		1
	ZX-03710B	Lead Screw (for 14"/16" models)		1
55	ZX-03101A-G	Tailstock Casting (for 18" models)		1
	ZX-03101B-G	Tailstock Casting (for 16" models)		1
	ZX-03101C-G	Tailstock Casting (for 14" models)		1
	GH2280ZX-03101-G	Tailstock Casting (for 22" model)		1
56	ZX-T56	Oil Cup	8	1
57	ZX-03708A	Dial		1
58	ZX-03706	Sleeve		1
59	ZX-03711C	Spring Leaf		1
65	TS-2310162	Nut	M16	1

# Tailstock Assembly II

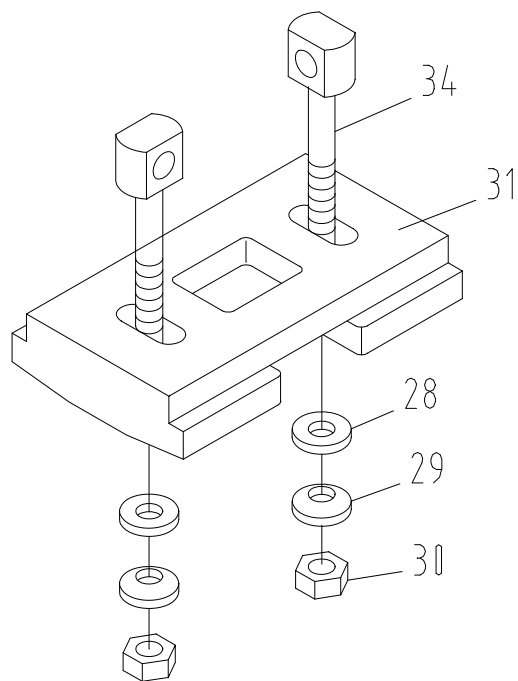
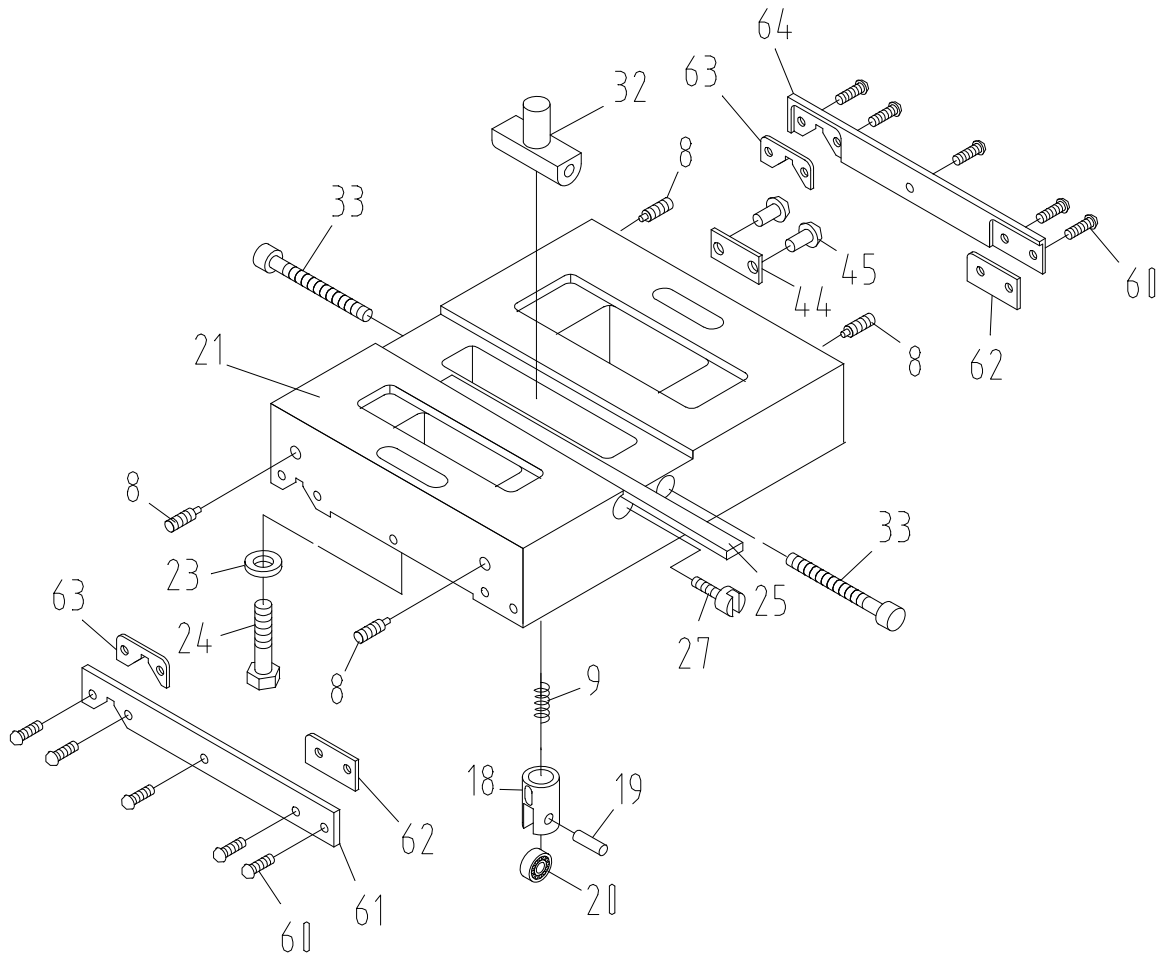

## Tailstock Assembly II

Index No.	Part No.	Description	Size	Qty.
8	ZX-T08	Flat End Set Screw (except in 14" models)	M6x18	4
9	ZXT09E	Spring (serial # 120120ZX2425 and higher)		1
18	ZX-03714	Bearing Support (except in 14" models)		4
19	ZX-03715	Small Axle (except in 14" models)		4
20	ZX-T20	Ball Bearing (except in 14" models)	7x19x6	4
21	ZX-03102A-G	Sliding Base (for 18"/22" models)		1
	ZX-03102B-G	Sliding Base (for 16" models)		1
	ZX-03102C-G	Sliding Base (for 14" models)		1
23	TS-1550071	Flat Washer	M10	2
24	TS-1491151	Hex Cap Bolt (for 18"/22" models)	M10x90	2
	TS-1491121	Hex Cap Bolt (for 16" models)	M10x70	2
	TS-1491081	Hex Cap Bolt (for 14" models)	M10x50	2
25	ZX-03704	Gib		1
27	ZX-03718C	Adjusting Screw		2
28	ZX-T28	Taper Washer	16	2
29	ZX-T29	Spherical Washer	16	2
30	TS-2310162	Hex Nut	M16	2
31	ZX-03106-G	Clamping Bracket		1
32	ZX-03105C	Nut		1
33	ZX-T33	Hex Socket Cap Screw	M8x85	2
34	ZX-03705A	Pulling Rod (for 18"/22" models)		2
	ZX-03705B	Pulling Rod (for 16" models)		2
	ZX-03705C	Pulling Rod (for 14" models)		2
44	ZX-03303	Sign Plate		1
45	ZX-T45	Nail	3x8	4
60	ZX-T60	Half Round Head Screw	M5 x12	10
61	ZX-03721	Plate		1
62	ZX-03502	Wipe Plate		2
63	ZX-03503	Wipe Plate		2
64	ZX-03716	Plate		1

# Steady Rest Assembly

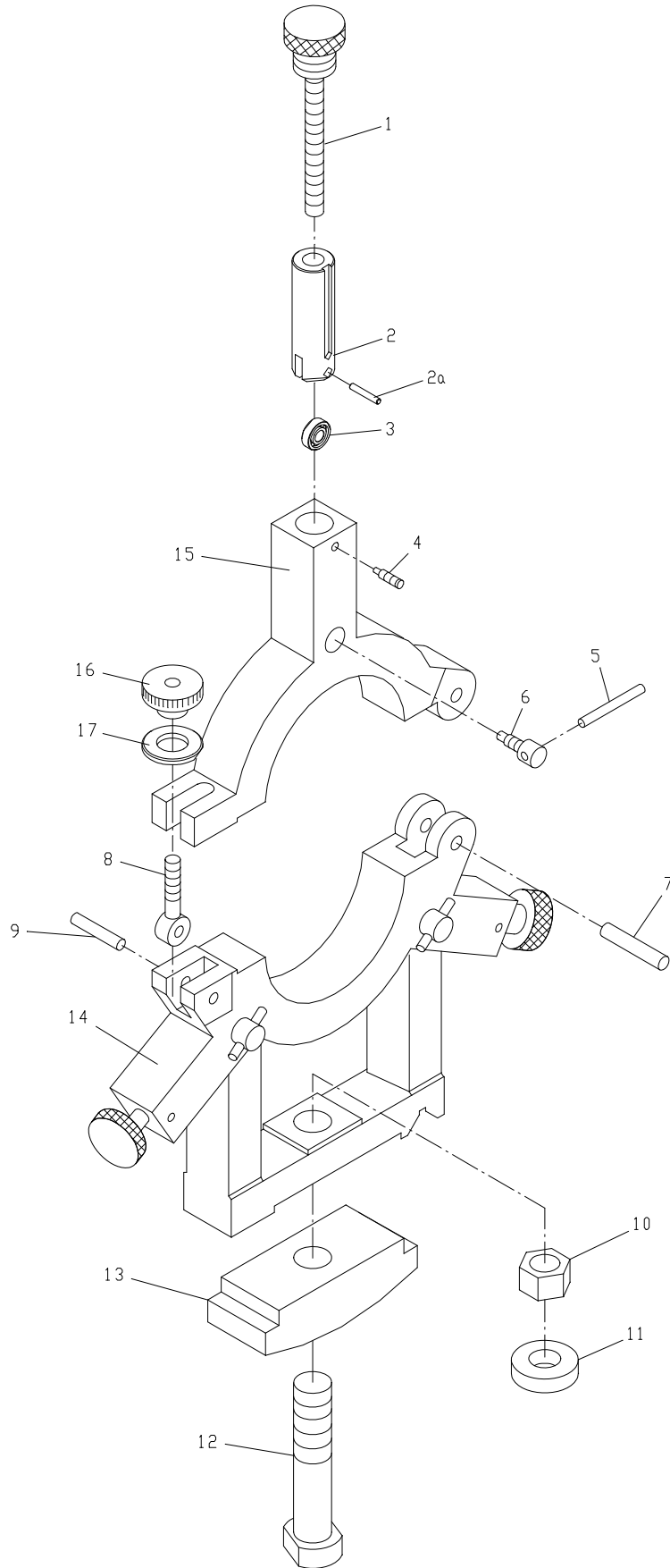

## Steady Rest Assembly

Index No.	Part No.	Description	Size	Qty.
1	ZX-10702D	Screw (for 14" models)		3
	ZX-10701E	Screw (for 16" models)		3
	ZX-10701F	Screw (for 18" /22" models)		3
2	ZX-10704G	Sliding Sleeve (for 14" models only) (serial #160410ZX3032 and higher)		3
			90-180	3
	ZX-10705E	Sliding Sleeve (for 16" models only) (serial #160410ZX3032 and higher)		3
			20-180	3
	ZX-10705E	Sliding Sleeve (for 18"/22" models) (serial #160410ZX3032 and higher)		3
			20-200	3
2a	GB119-8n6x24	Pin (serial #160410ZX3032 and higher)	8n6x24	3
3	608-RS	Bearing (serial #160410ZX3032 and higher)	8x22x7	3
4	ZX-SR04	Slotted Set Screw	M6x20	3
5	ZX-10705	Lever		3
6	ZX-10703D	Locking Screw		3
7	GB119-10n6x55	Pin	10n6x55	1
8	ZX10701	Hinge Screw		1
9	GB119-8n6x55	Pin	8n6x55	1
10	ZX-SR10	Hex Nut	M20	1
11	ZX-SR11	Flat Washer	20	1
12	ZX-10708	Tightening Screw		1
13	ZX-10103D-G	Clamping Plate		1
14	ZX10101D-G	Lower Part of Steady Rest (for 14" models)		1
	ZX10101E-G	Lower Part of Steady Rest (for 16" models)		1
	ZX10101F-G	Lower Part of Steady Rest (for 18" models)		1
	GH2280ZX-10101-G	Lower Part of Steady Rest (for 22" model)		1
15	ZX10102D-G	Upper Part of Steady Rest (for 14" models)		1
	ZX10102E-G	Upper Part of Steady Rest (for 16" models)		1
	ZX10102F-G	Upper Part of Steady Rest (for 18" /22" models)		1
16	ZX-10701D	Knurling Nut		1
17	GB97.2-10	Flat Washer	10	1
	ZX-SRA14-G	Steady Rest Assembly, 14" (includes # 1-17)		
	ZX-SRA16-G	Steady Rest Assembly, 16" (includes # 1-17)		
	ZX-SRA18-G	Steady Rest Assembly, 18" (includes # 1-17)		
	ZX-SRA22-G	Steady Rest Assembly, 22" (includes # 1-17)		

# Follow Rest Assembly

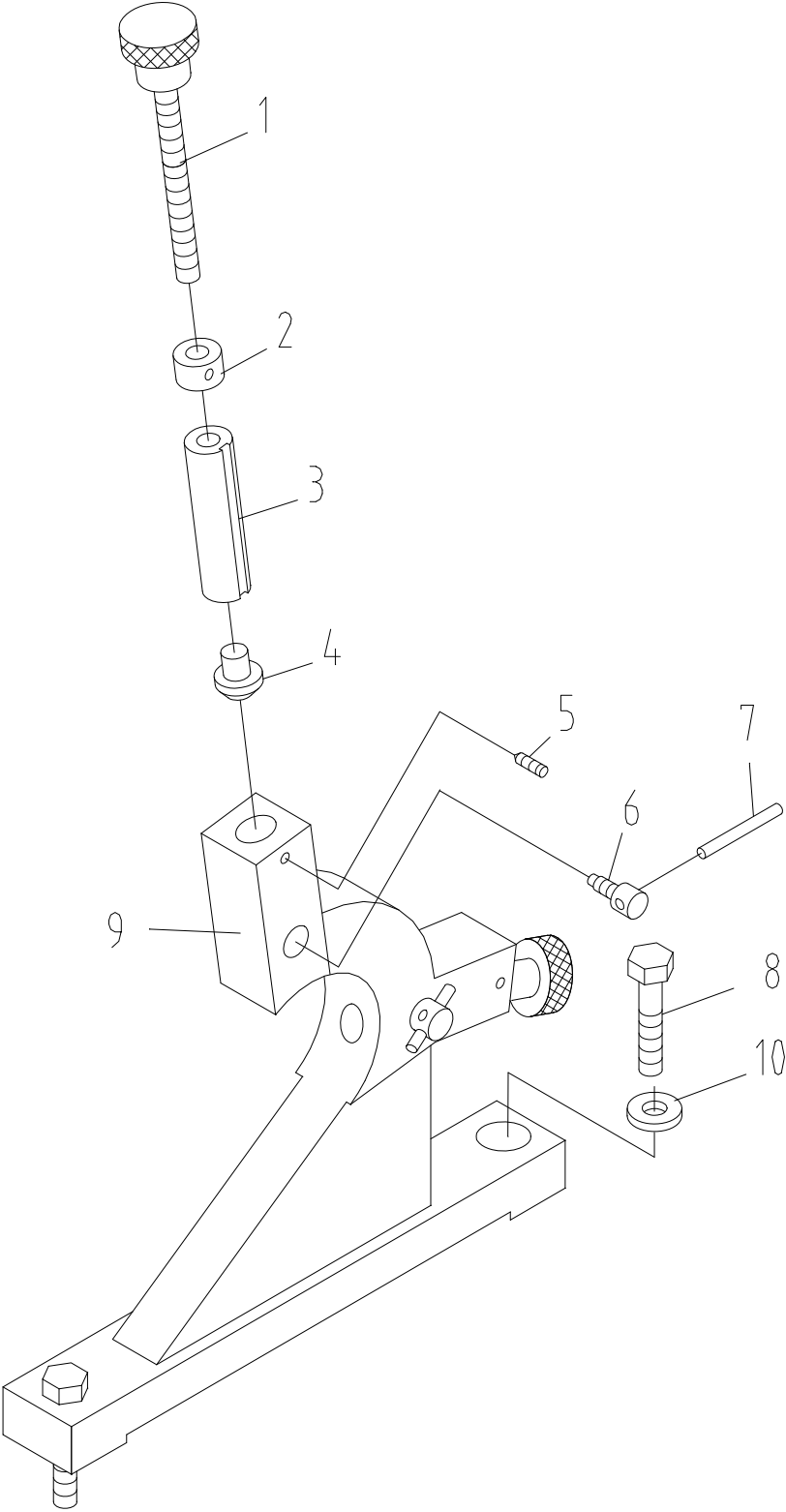

## Follow Rest Assembly

Index No.	Part No.	Description	Size	Qty.
1	ZX-10710	Screw		2
2	ZX-10704	Nut		2
3	ZX-10707	Sliding Sleeve		2
4	ZX-10301	Supporting Piece		2
5	ZX-FR05	Slotted Set Screw	M6x10	2
6	ZX-10705	Locking Screw		2
7	ZX-10706	Handle		2
8	ZX-FR8	Hex Cap Bolt	M12x55	2
9	ZX-10102A-G	Follow Rest Casting (for 14" models)		1
	ZX-10102B-G	Follow Rest Casting (for 16" models)		1
	ZX-10102C-G	Follow Rest Casting (for 18" models)		1
	GH2280ZX-10102-G	Follow Rest Casting (for 22" model)		1
10	ZX-FR10	Flat Washer	12	2
	ZX-FRA14-G	Follow Rest Assembly, 14" (includes #1-7,9)		
	ZX-FRA16-G	Follow Rest Assembly, 16" (includes #1-7,9)		
	ZX-FRA18-G	Follow Rest Assembly, 18" (includes #1-7,9)		
	ZX-FRA22-G	Follow Rest Assembly, 22" (includes #1-7,9)		



# Coolant & Work Light Assembly

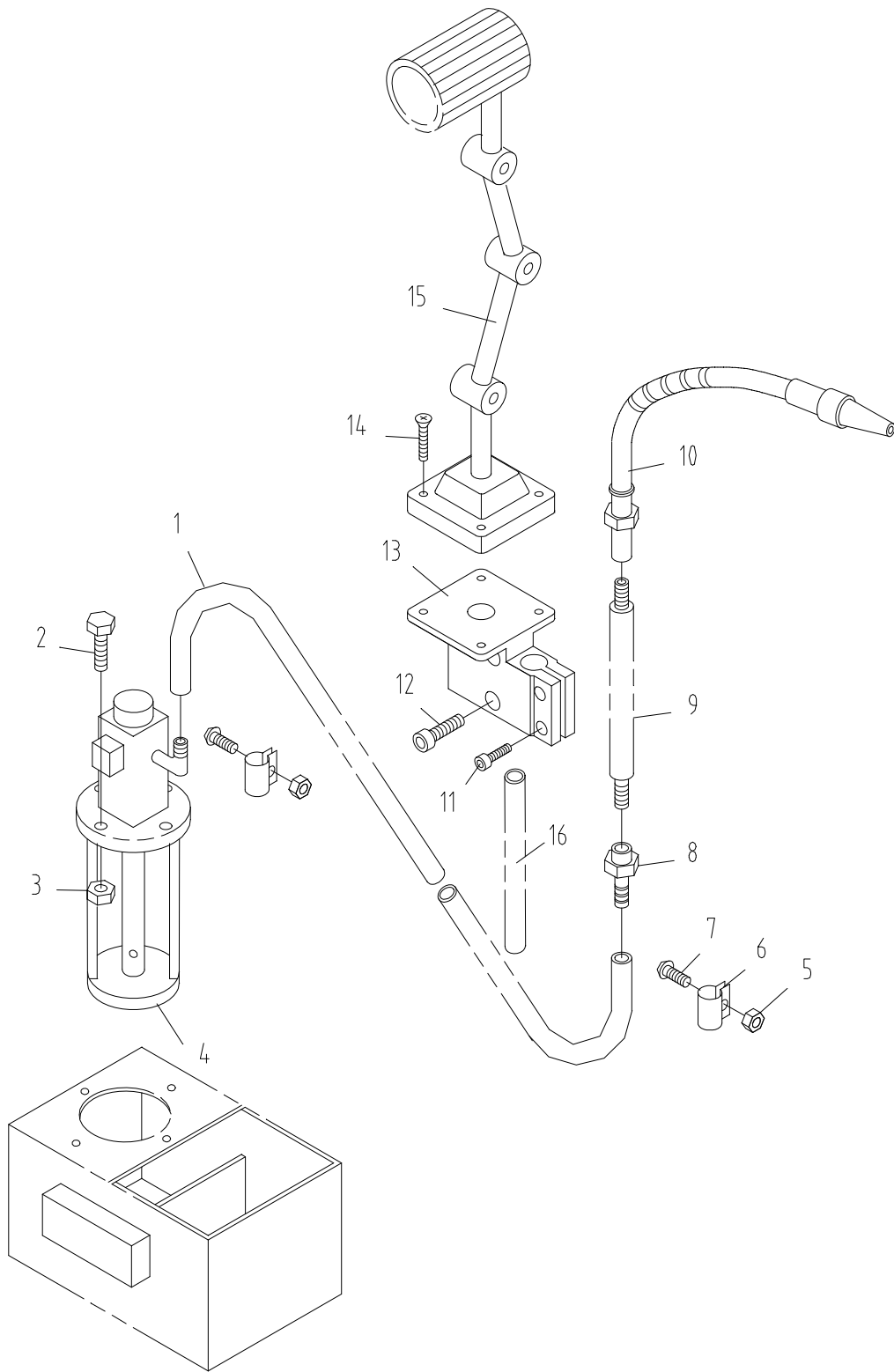

## Coolant & Work Light Assembly

Index No.	Part No.	Description	Size	Qty.
1	RT-001A	Rubber Tube (for 1440/1640/1840ZX)	ID 1/2"x1280mm	1
	RT-001B	Rubber Tube (for 1460/1660/1860ZX)	ID 1/2"x1780mm	1
	RT-001C	Rubber Tube (for 1880/2280ZX)	ID 1/2"x2280mm	1
2	ZX-CW02	Hex Cap Bolt	M5x25	4
3	ZX-CW03	Hex Nut	5	4
4	ZX-CW04	Coolant Pump (serial #140925ZX2825 and lower)		1
	ZX-CW04A	Coolant Pump (serial #140925ZX2826 and higher)		1
5	ZX-CW05	Hex Nut	M6	2
6	ZX-01727	Clip For Rubber Tube		2
7	ZX-CW07	Half Round Head Screw	M6x16	2
8	ZX-01728	Fitting		1
9	ZX-01729	Flow Pipe		1
10	ZX-CW10	Coolant Device		1
	ZX-CW10-1	Coolant Tap	G 3/8"	1
11	TS-1514021	Hex Socket Cap Screw	M6x16	2
12	TS-1515051	Hex Socket Cap Screw	M8x40	2
13	ZX-CW13	Lamp Support		1
14	ZX-S04	Cross Head Screw	M6x14	4
15	ZX-CW15	Lamp Frame (serial #160401ZX3031 and lower)		1
	ZX-CW16	Bulb (serial #160401ZX3031 and lower)	50W, AC24V	1
	ZX-EL	Machine lamp (serial #160410ZX3032 and higher)	JC52B	1
16	ZX-WLCP01	Tube (for 40" models)	1.7m	1
	ZX-WLCP02	Tube (for 60" models)	2.2m	1
	ZX-WLCP03	Tube (for 80" models)	2.7m	1

## Other Parts

Index No.	Part No.	Description	Size	Qty.
1A	ZX-OP-1A	3-Jaw Chuck (mounted on lathe)	10", D1-8	1
1B	ZX-OP-1B	Chuck Wrench		1
3	ZX-OP-03	12" Face Plate (for 14"/16" models)		1
	ZX-OP-03N	16" Face Plate (for 18"/22" models)		1
5	ZX-OP-05	Cam Tightening Wrench		1
6	ZX-OP-06	Center		1
7	ZX-OP-07	MT-4 Live Center (for 14"/16" models)		1
	ZX-OP-07N	MT-5 Live Center (for 18"/22" models)		1
8	ZX-OP-08	Morse Reduction Sleeve		1
9	ZX-OP-09	Oil Gun		1
10	ZX-OP-10	Touchup Paint Can		1
11	ZX-OP-11	Gap Bridge Pin Driver		1
12	ZX-OP-12	Hex Wrench	2,2.5,3,4,5,6,8,10	8
13	ZX-OP-13	Double End		1
14	ZX-OP-14	Flat Blade Screw Driver		1
15	ZX-OP-15	Cross Point Screw Driver		1
16	ZX-OP-16	Adjustable Wrench		1
17	ZX-OP-17	Round Nut Wrench		1
18	ZX-OP-18	Shear Pin		2
21	ZX-OP-21	Indicate Bulb (serial # 160401ZX3031 and lower)	110V or 24V	1
	ZX-HL	Indicate Bulb (serial #160410ZX3032 and higher)	XB7-EVF3LC	1
22	ZX-OP-22	Taper Piece		1
23	ZX-OP-23	Gear	3.5m36T (14"/16" /22")	1
	ZX-OP-23	Gear	4m36T (18")	1
24	ZX-OP-24	Leveling Pads		6
25	ZX-250-401	Tool Holder (serial # 160410ZX3032 and higher)		1
26	ZX-250-404	Tool Holder (serial # 160410ZX3032 and higher)		1
27	ZX-250-407	Tool Holder (serial # 160410ZX3032 and higher)		1
28	ZX-250-410	Tool Holder (serial # 160410ZX3032 and higher)		1
29	GB5782-M12×40	Hex Head Cap Screw	M12×40	2
30	GB97.2-12	Flat Washer	12	2
31	ZX-10705E	Sliding Sleeve Assembly (for 14" models only)	20-110	3pair

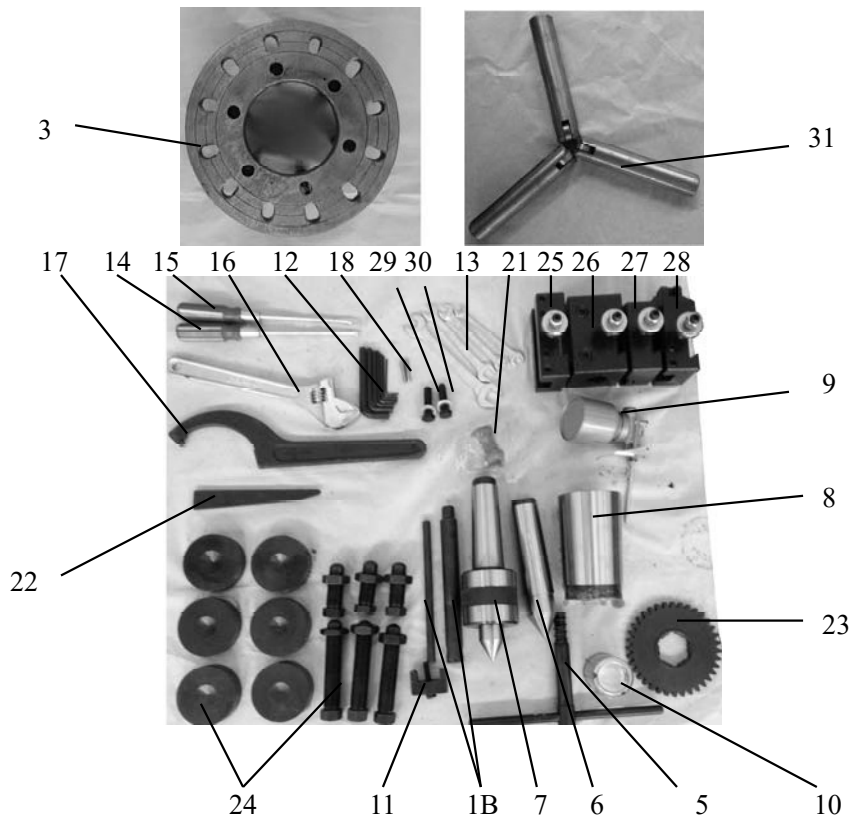

## Electrical Cabinet

Index No.	Part No.	Description	Size	Qty.
1	ZX-SB1	Jog Button (serial #160401ZX3031 and lower)	LAY3-11	1
	ZX-SB3	Jog Button (serial #160410ZX3032 and higher)	XB2-EA131	1
2	ZX-SA2	Coolant Control Button	ZB2-BD2C	1
3	ZX- SB2	Emergency Stop (serial #160410ZX3032 and higher)	ZB2-BS54C	1
3a	ZX- SB2	Emergency Stop (serial #160401ZX3031 and lower)	LAY3-012S/1	1
	ZX- SB2	Emergency Stop (serial #160410ZX3032 and higher)	ZB2-BS54C	1
4	ZX-HL	Power Indicator Light (serial #160401ZX3031 and lower)	XD11-30/20	1
	ZX-HL	Power Indicator Light (serial #160410ZX3032 and higher)	XB7-EVF3LC	1
5	ZX-SQ2	Stroke Switch	JW2-11H/W1	1
6	ZX-QF	Master Switch (40A) (serial #160401ZX3031 and lower)	D215-40	1
	ZX-QF	Breaker (serial #160410ZX3032 and higher)	NSC100B	1
7	ZX-FU1	Fuse (2A) (serial #160401ZX3031 and lower)	JRT1-16A	1
	ZX-QF1	Breaker (serial #160410ZX3032 and higher)	DZ47-63	1
8	ZX-FU2	Fuse (3A) (serial #160401ZX3031 and lower)	JRT1-16A	1
	ZX-FU3	Fuse (3A) (serial #160401ZX3031 and lower)	JRT1-16A	1
	ZX-FU5	Fuse (3A) (serial #160401ZX3031 and lower)	JRT1-16A	1
	ZX-FB	Fuse Block (serial #160401ZX3031 and lower)		1
	ZX-QF2-QF4	Breaker (serial #160410ZX3032 and higher)	DZ47-63	3
9	ZX-KM1	A.C. Contactor (for 14", 16", 18" models)	3TB43	1
	GH2280ZX-KM1	A.C. Contactor (for 22" models)	3TB44	1
9a	ZX-KM2	A.C. Contactor (for 14", 16", 18" models)	3TB43	1
	GH2280ZX-KM2	A.C. Contactor (for 22" models)	3TB44	1
10	ZX-KM3	A.C. Contactor	3TB40	1
11	ZX-KA1	Relay	3TB80	1
12	ZX-KA2	Relay (serial #160410ZX3032 and higher)	HH52P	1
13	ZX-TC	Control Transformer (serial #160401ZX3031 and lower)	JBK3-100-TH	1
	ZX-TC	Control Transformer (serial #160410ZX3032 and higher)	JBK5-160-TH	1
14	ZX-SA3	Switch	HZ3-134	1
15	ZX-PX1	Switch	LJ12A3-4-J/EZ	1
16	ZX-EL	Machine lamp	JC52B	1
17	ZX-18703B-G	Electric Box		1
18	ZX-18703/9B	Electric Box Door (serial #160410ZX3032 and higher)		1
19	GH1640ZX-18301E	Operation Panel (serial #160401ZX3031 and lower)		1
	ZX-18301F	Operation Panel (serial #160410ZX3032 and higher)		1
20	AS-04	Digital Display Plug (serial #160410ZX3032 and higher)		1
21	ZX-XB	Copper Plate (for grounding)		1
22	ZX-XT1	Wiring Board		1
23	ZX-XT2	Wiring Board		1

# Electrical Cabinet

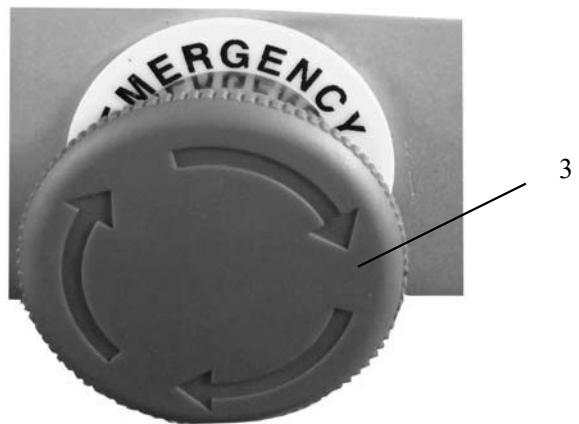
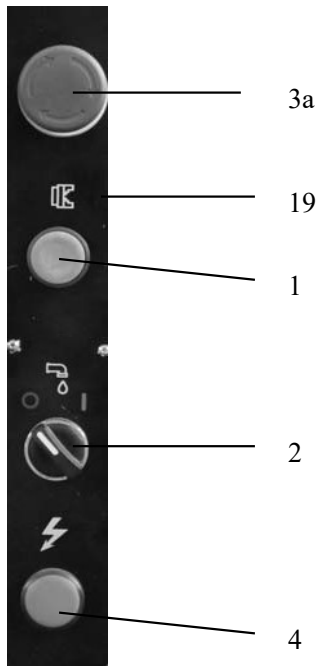
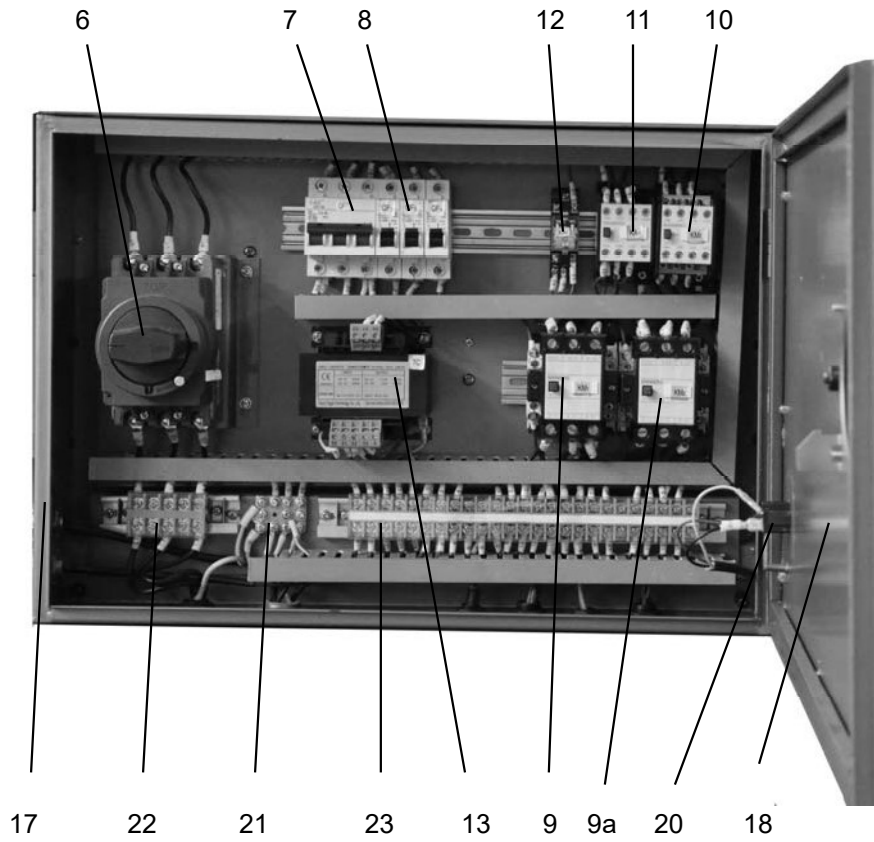

# Wiring Diagram

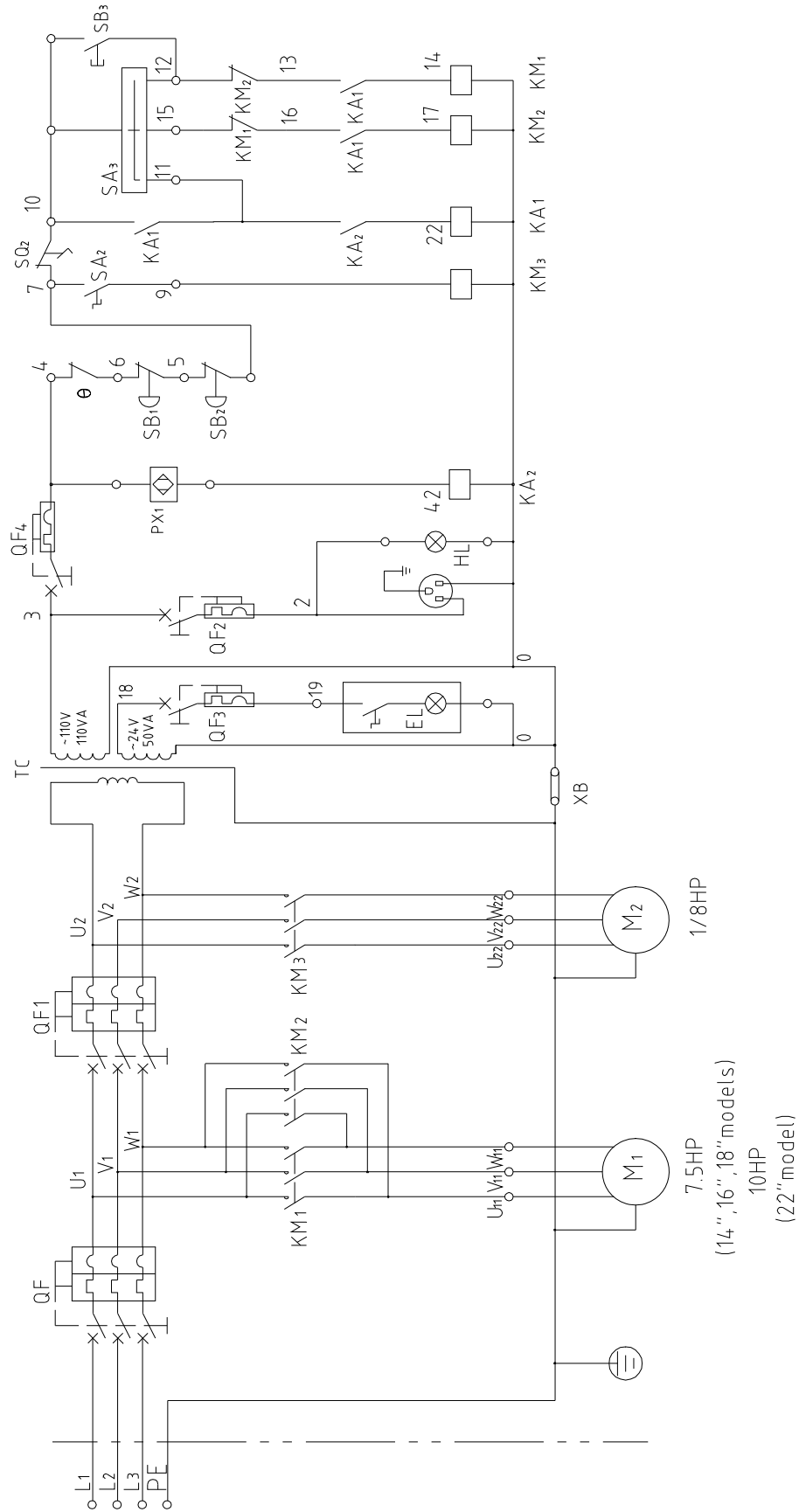

## Rotary Switch Diagram

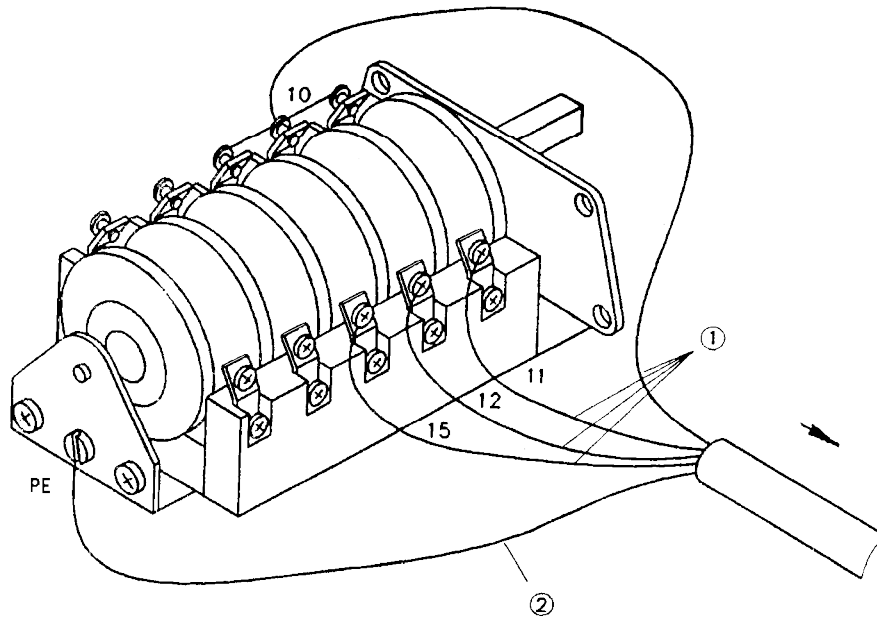

1.....The Cord from the Wiring Board (part no. ZX-XT2)

2.....The Grounding Wire from the Copper Plate (part no. ZX-XB)

## Safety Guard Cover

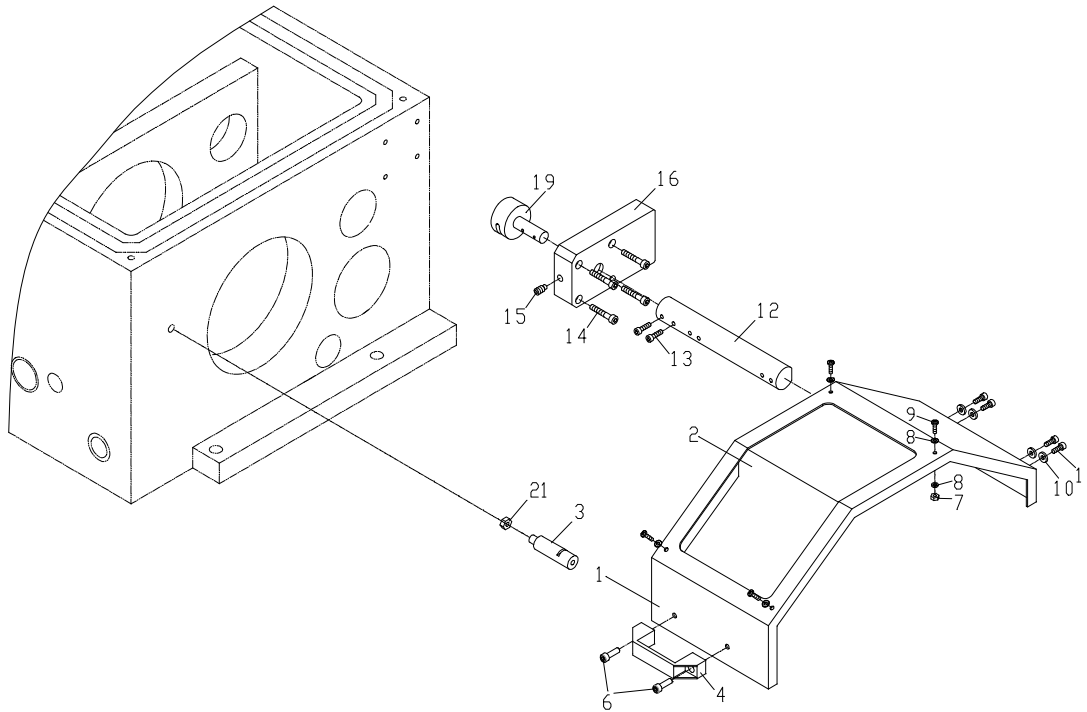

Index No.	Part No.	Description	Size	Qty.
1	ZX19701E-G	Protection guard		1
2	ZX19501E	Protection guard visual glass		1
3	ZX19704E	Fixing rod		1
4	ZXS04E	Handle (serial #160401ZX3031 and lower)	Z96-6	1
	A=90 Black	Handle (serial #160410ZX3032 and higher)		1
5	ZX-S05E	Plain washer (serial #160401ZX3031 and lower)	6	2
6	ZX-S06E	Cross-recessed pan head screw (serial #160401ZX3031 and lower)		
			M6x12	2
	GB70- M6x12	Hex Socket Cap Screw (serial #160410ZX3032 and higher)		
			M6x12	2
7	ZXS07E	Hexagon thin nuts	M4	4
8	ZXS08E	Plain washers	4	8
9	ZXS09E	Cross recessed pan head screws	M4x12	4
10	ZXS10E	Plain washers	5	4
11	ZXS11E	Hexagon socket cap head screws	M5x16	4
12	ZX19703E	Rest bar		1
13	ZXS13E	Slotted set screws	M8x10	2
14	ZXS14E	Hexagon socket cap head screws	M6x35	4
15	ZXS15E	Hexagon socket set screws	M8x16	1
16	GH1440A19101E	Switch box		1
19	ZX19702E	Shaft		1
21	ZXS21E	Nut	M8	1

(Note: This device is installed from serial #110825ZX2338)



## Carriage lubrication

Index No.	Part No.	Description	Size	Qty.
1	ARM	Valve Tie-in		1
2	206254	Clip Sleeve	CS-6	2
3	206252	Vitta Tie-in	CB-6	2
4	CL-04	Nylon Pipe	Φ6	0.4m
5	CL-05	Spring Sleeve	Φ6	0.2m
5a	PC-4-1	Nip	Φ4	3
5b	GB70- M5×10	Hex Socket Cap Screw	M5×10	3
6	106095	Tie-in	SA-4-6	1
7	CL-07	Tie-in	KC-4	4
8	CL-08	Nylon Pipe	Φ4	0.7m
9	CL-09	Spring Sleeve	Φ4	0.7m
10	106252	Vitta Tie-in	CB-4	4
11	106254	Clip Sleeve	CS-4	4
12	106255	Plug	CP-4	1
13	106411	Connector	PJ-6D	1
14	GB70 M5×20	Hex Socket Cap Screw	M5×20	2

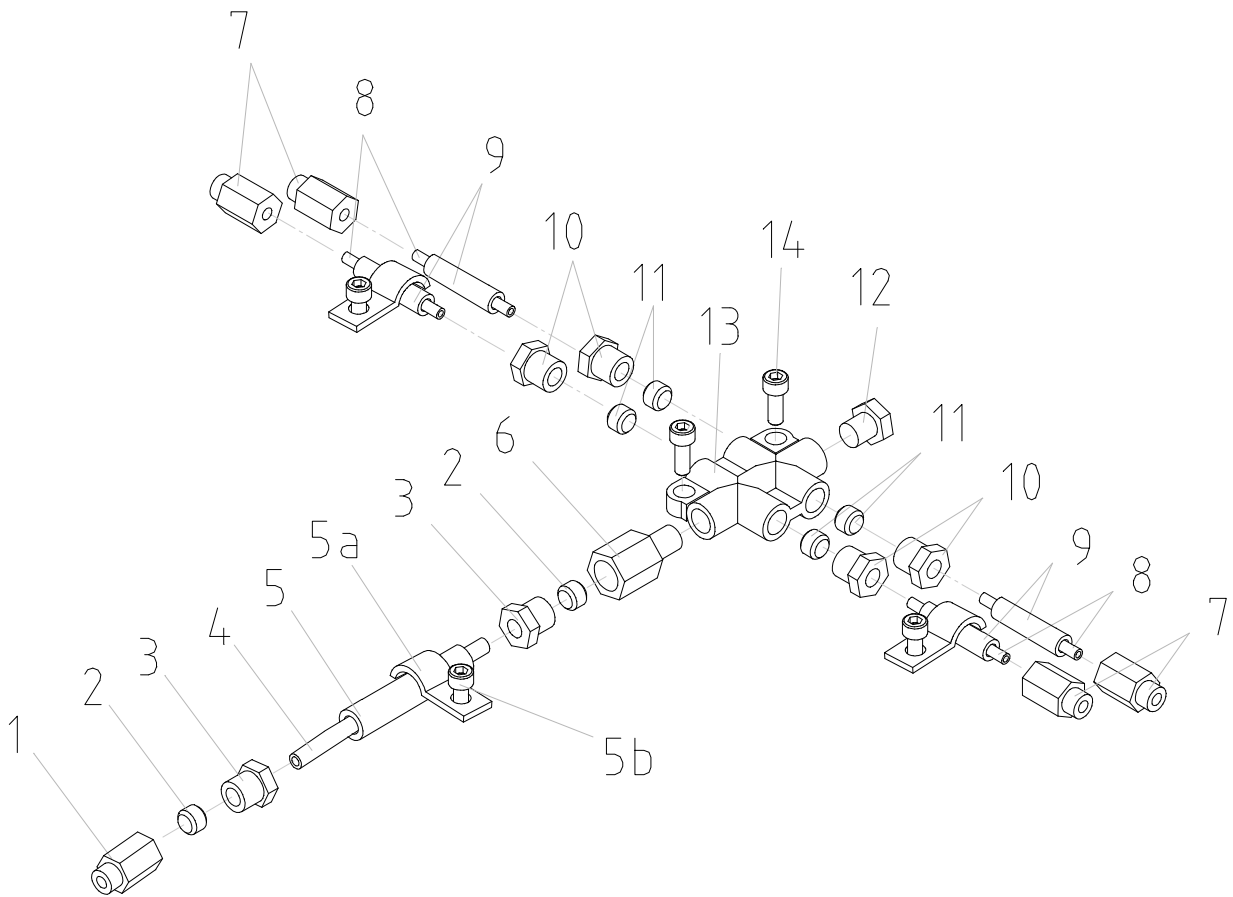

(Note: This device is installed from serial #140925ZX2822)