



DDS-225 DUAL DRUM SANDER

DDS-225.....1791290T.....3~400V, 50Hz

PARTS LIST

TOOL FRANCE SARL
9 Rue des Pyrénées, 91090 LISSES, France
www.jettools.com



DDS-225 Drum Assembly

Index No.	Part No.	Description	Size	Qty.
1	DDS225-101A	Rear Drum		1
2	DDS225-102A	Abrasive Fastener-Right		2
3	DDS225-103A	Abrasive Fastener-Left		2
4	DDS225-104	Spring		2
5	DDS225-105	Locking Wedge		4
6	DDS225-106	Abrasive (80 Grit)		1
	DDS225-106A	Abrasive (100 Grit)		1
7	DDS225-107	Support Bracket		2
8	DDS225-108	Pulley		2
9	DDS225-109	Tension Roller		3
10	DDS225-110	Bushing		6
11	DDS225-111	Spring		6
12	DDS225-112	Bracket		6
13	DDS225-113	Bearing Assembly	UCFL205	4
14	VB-B68	Belt		2
15	DDS225-115	Key	8 x 7 x 50	2
16	DDS225-116	Adjusting Bushing		6
17	TS-0561031	Hex Nut	3/8-16	2
18	DDS225-118	Hex Cap Screw	5/16-18 x 5/8	12
19	TS-0720081	Lock Washer	5/16	12
20	TS-0060071	Hex Cap Screw	3/8-16 x 1-1/4	8
21	DDS225-121	Hex Cap Screw	1/2-13 x 1-1/2	4
22	TS-0720111	Lock Washer	1/2	8
23	DDS225-123	Hex Cap Screw	3/8-16 x 1-3/4	4
24	TS-0720091	Lock Washer	3/8	8
25	TS-1550071	Flat Washer	M10	4
26	TS-0207061	Socket Head Cap Screw	1/4-20 x 1	4
27	DDS225-127	Socket Set Screw	5/16-18 x 1/2	4
28	DDS225-128	Hex Cap Screw	3/8-16 x 3/4	4
29	TS-0060051	Hex Cap Screw	3/8-16 x 1	2
30	TS-0208021	Socket Head Cap Screw	5/16-18 x 1/2	4
31	TS-0270051	Socket Set Screw	5/16-18 x 1/2	2
32	DDS225-132	Spring		2
33	DDS225-133	Steel Ball	Ø1/4	2
34	DDS225-134	Socket Set Screw	1/4-20 x 1/4	4
35	DDS225-135	Adjusting Knob		2
36	DDS225-136	Lead Screw		2
37	TS-0207041	Socket Head Cap Screw	1/4-20 x 3/4	4
38	TS-0680061	Flat Washer	1/2	4
39	TS-0720071	Lock Washer	1/4	4
40	DDS225-140	Top Cover-Right		1
41	DDS225-141	Collar		2
42	DDS225-142	Slide		2
43	DDS225-143	Locking Lever		2
44	DDS225-144	Slide Bracket-Right		1
45	TS-0561011	Hex Nut	1/4-20	4
46	TS-0267091	Socket Set Screw	1/4-20 x 1	4
47	DDS225-147	Gib-Right		1
48	DDS225-148	Top Cover-Left		1

DDS-225 Drum Assembly

Index No.	Part No.	Description	Size	Qty.
49.....	TS-1541041.....	Hex Nylon Lock Nut.....	M10.....	6
50.....	DDS225-150.....	Adjusting Screw.....		6
51.....	DDS225-151.....	Hex Nut.....	M22 x 1.5P x 5T.....	6
52.....	DDS225-152.....	Slide Bracket-Left.....		1
53.....	DDS225-153.....	Gib-Left.....		1
54.....	DDS225-154A.....	Front Drum.....		1
55.....	TS-1521021.....	Socket Set Screw.....	M4 x 10L.....	4
56.....	DDS225-156.....	Hex Cap Screw.....	1/2-13x 1-1/4.....	4
57.....	TS-0720091.....	Lock Washer.....	3/8.....	8
58.....	DDS225-158.....	Roll Pin.....	Ø2 x 8mm.....	2
59.....	DDS225-159.....	Pulley Guard.....		1
60.....	DDS225-160.....	Bracket.....		2
61.....	DDS225-161.....	Flat Washer.....	1/4".....	4
62.....	DDS225-162.....	Screw.....	1/4"-20 x 3/8.....	6
.....	DDS225-LSBA.....	Left Slide Bracket Assembly..... (index # 31-37 ,39, 41-43, 45-46, 48,52,53, 55,58)		1
.....	DDS225-RSBA.....	Right Slide Bracket Assembly (index #31-37 ,39-47, 55,58)		1

DDS-225 Drum Assembly

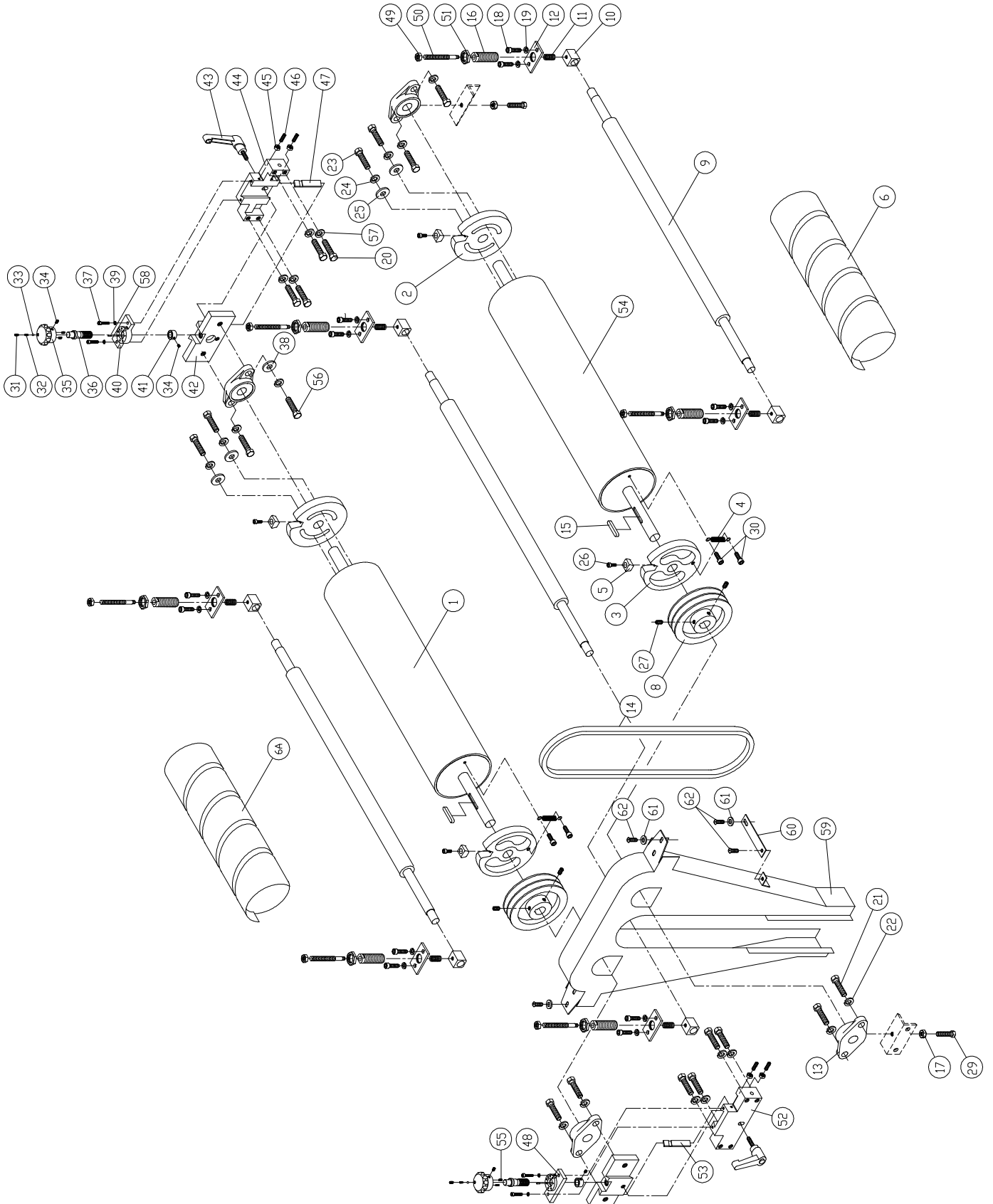

DDS-225 Conveyor Assembly

Index No.	Part No.	Description	Size	Qty.
1.....	DDS225-201.....	Table		1
2.....	DDS225-202.....	Support Bracket, Left-Front		1
3.....	DDS225-203.....	Support Bracket, Right-Front		1
4.....	DDS225-204.....	Support Bracket, Left-Rear		1
5.....	DDS225-205.....	Support Bracket, Right-Rear.....		1
6.....	DDS225-206B	Leadscrew Holder, Right-Front.....		1
7.....	DDS225-207B	Leadscrew Holder, Left-Front and Right-Rear.....		2
8.....	DDS225-208.....	Rod		1
9.....	DDS225-209.....	Front Roller		1
10.....	DDS225-210.....	Front Support Plate.....		1
11.....	DDS225-211.....	Collar.....		2
12.....	DDS225-212.....	Adjusting Knob.....		2
13.....	DDS225-213.....	Rear Roller.....		1
14.....	DDS225-214.....	Rear Support Plate		1
15.....	DDS225-215A	Drive Leadscrew		1
16.....	DDS225-216A	Driven Leadscrew		3
17.....	DDS225-217.....	Sprocket.....		4
18.....	DDS225-218.....	Support Bracket		8
19.....	DDS225-219.....	Guide Plate		2
20.....	DDS225-220.....	Post.....		1
21.....	DDS225-221.....	Handle.....		1
22.....	DDS225-222.....	Pointer.....		1
23.....	DDS225-223.....	Collar.....		2
24.....	DDS225-224.....	Bolt.....		1
25.....	BB-6203ZZ	Ball Bearing.....	6203ZZ.....	4
26.....	DDS225-226.....	Thrust Bearing		4
27.....	DDS225-227.....	Roll Pin.....	Ø6 x 25mm	1
28.....	DDS225-228.....	Chain.....		1
29.....	TS-081F022	Phillips Pan Head Machine Screw	1/4-20 x 3/8.....	1
30.....	TS-0050011	Hex Cap Screw	1/4-20 x 1/2.....	8
31.....	TS-0207111	Socket Head Cap Screw.....	1/4-20 x 2-1/4.....	16
32.....	TS-0720071	Lock Washer.....	1/4.....	16
33.....	DDS225-233.....	Hex Nut.....	7/8-9.....	4
34.....	DDS225-234.....	Key.....	5 x 5 x 18mm	4
35.....	DDS225-235.....	Socket Head Cap Screw.....	5/16-18 x 3/4.....	16
36.....	TS-0720081	Lock Washer.....	5/16.....	22
39.....	TS-1550061	Flat Washer	M8.....	16
40.....	DDS225-240.....	Bushing		1
41.....	DDS225-241.....	Conveyor.....		1
42.....	TS-0561031	Hex Nut.....	3/8-16.....	1
43.....	DDS225-243.....	Front Cover		1
44.....	DDS225-244.....	Rear Cover.....		1
45.....	DDS225-245B	Threaded Bushing.....		4
46.....	DDS225-246.....	Handwheel		1
47.....	DDS225-247.....	Socket Set Screw.....	5/16-18 x 1/2.....	2
48.....	DDS225-248B	Leadscrew Holder, Left-Rear		1
49.....	TS-0208041	Socket Head Cap Screw.....	5/16-18 x 3/4.....	6
50.....	TS-0680031	Flat Washer	5/16.....	12

DDS-225 Conveyor Assembly

Index No.	Part No.	Description	Size	Qty.
51	TS-0720081	Lock Washer	5/16	6
52	TS-0640081	Hex Nut	5/16-18	6
53	TS-0208021	Socket Head Cap Screw	5/16-18 x 1/2	6
54	DDS225-254	Hex Nut	1/4-20	8
55	TS-0050081	Hex Head Screw	1/4-20 x1-3/4	8
56	DDS225-256	Shield		1
57	TS-0680021	Flat Washer	1/4	10
58	DDS225-258	Screw	1/4-20 x1/4	2
59	DDS237-259	Upper Bracket		4
60	DDS237-260	Boot	1/4-20 x1/4	4
61	TS-081C022	Screw	3/16-24x3/8	8
62	TS-0680011	Flat Washer	3/16	8
63	DDS237-257	lower Bracket		4
65	DDS225-336	Hex Head Screw	1/4-20 x3/8	8
66	DDS237-266	Special Washer		4
67	TS-0267051	Set Screw	1/4-20x3/4	6
68	DDS225-268	Special Nut		4
69	TS-0267021	Set Screw	1/4-20x1/4	2

DDS-225 Conveyor Assembly

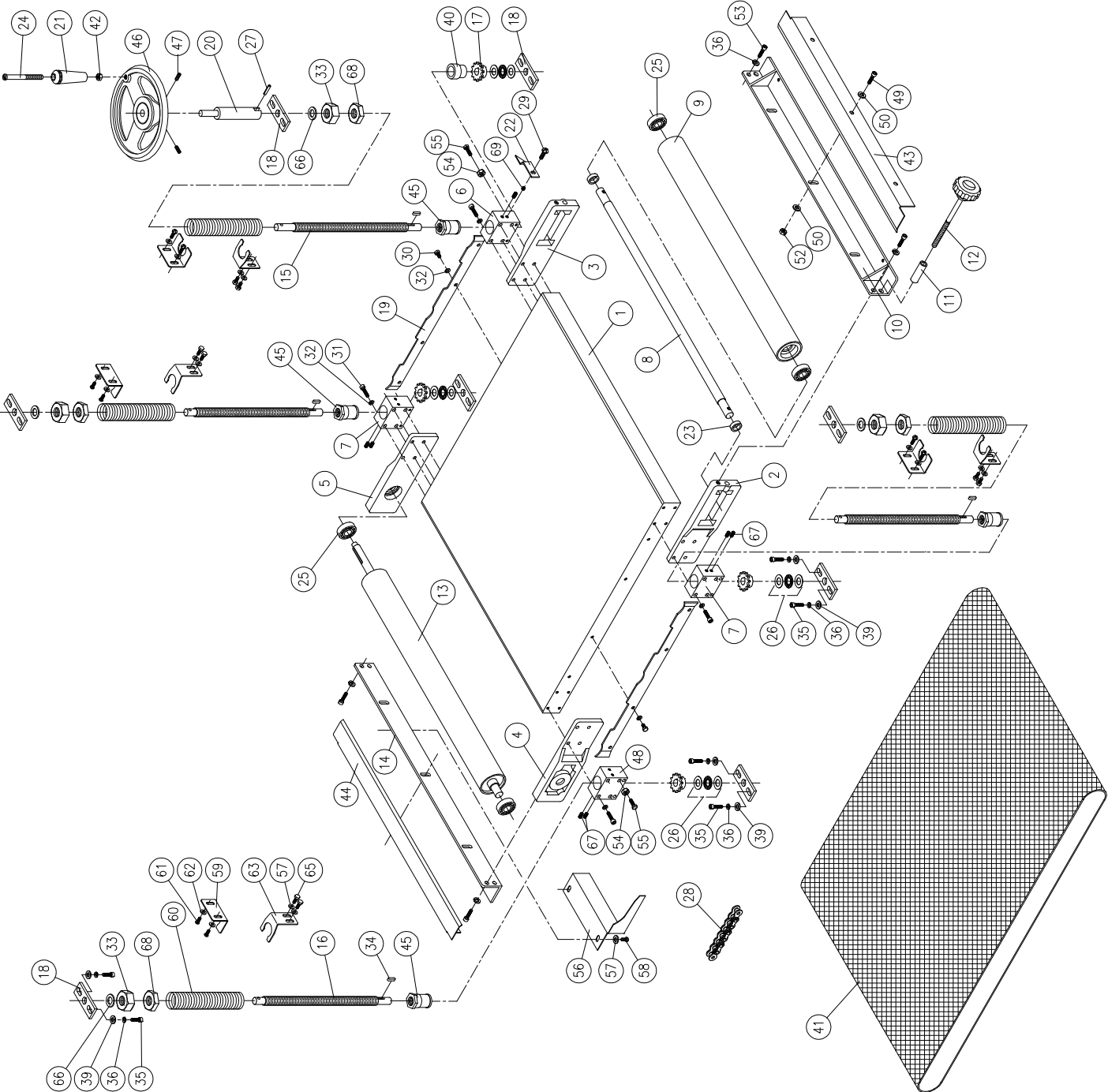

DDS-225 Motor & Cabinet Assembly

Index No.	Part No.	Description	Size	Qty.
1	DDS225-301A	Cabinet		1
2	DDS225-302	Support Bracket-Front		1
3	DDS225-303	Support Bracket-Rear		1
4	DDS225-304	Motor Plate		1
5	DDS225-305	Motor Pulley		1
6	DDS225-306AE	Motor	5HP, 3Ph, 400V	1
7	DDS225-307	Adjusting Screw		2
8	DDS225-308	Hinge		2
9	DDS225-309	Fixed Block		1
10	DDS225-310	Cylinder		1
11	DDS225-311	Flow Deflector		1
12	DDS225-312A	Top Cover		1
13	DDS225-313	Dust Chute		2
14	DDS225-314A	Roller Holder		1
15	DDS225-315	Idle Roller		1
16	DDS225-316	Switch Bracket		1
17	DDS225-317	Direction Label		1
18	DDS225-318E	Scale		1
19	DDS225-319A	Spacer		1
20	DDS225-320	Right Door Latch		2
	DDS225-320A	Left Door Latch		1
21	DDS225-321	Handle		1
22	DDS225-322AE	Magnetic Switch		1
	DDS225-322AEC	Contact		1
	DDS225-322AEO	Overload		1
23	DDS225-323AE	Power Cord		1
24	DDS225-324AE	Strain Relief		5
25	DDS225-325	Key	5 x 5 x55 mm	1
26	DDS225-326	Screw	3/16-24 x 1/2	18
27	TS-0720051	Lock Washer	#10	2
28	DDS225-328	Socket Head Cap Screw	3/8-16 x 3/4	6
29	TS-0720091	Lock Washer	3/8	10
30	TS-1550071	Flat Washer	M10	4
31	DDS225-313	Socket Head Cap Screw	M8 x25	1
32	TS-0207021	Socket Head Cap Screw	1/4-20 x 1/2	1
33	TS-0720071	Lock Washer	1/4	21
34	DDS225-334	Shoulder Screw	M8 X1.25P X11	1
35	DDS225-335	Hex Nylon Lock Nut	M8	2
36	DDS225-336	Hex Head Screw	1/4-20 X 1/2	6
37	TS-0680021	Flat Washer	1/4	16
38	TS-0050011	Hex Cap Screw	1/4-20 x 1/2	6
39	TS-0208041	Socket Head Cap Screw	5/16-18 x 3/4	2
40	TS-0561021	Hex Nut	5/16-18	3
41	DDS225-341	Socket Head Cap Screw	5/16-18 x 1	1
42	DDS225-342	Flat Washer	M8	1
43	DDS225-343	Socket Set Screw	5/16-18 x 1/2	2
44	TS-0561031	Hex Nut	3/8-16NC	10
45	DDS225-345	Hex Cap Screw	3/8-16NC x 1-1/2	4
46	DDS225-346	Shoulder Screw		1
47	TS-0208061	Hex Cap Screw	5/16-18 x 1	1
48	TS-081F032	Phillips Pan Head Machine Screw	1/4-20 x 1/2	4
50	DDS225-350	Label (Drum Setting Gauge)		2

DDS-225 Motor & Cabinet Assembly

Index No.	Part No.	Description	Size	Qty.
51.....	DDS225-351.....	Flat Washer	5/16.....	1
52.....	DDS225-352.....	Flat Washer	3/8.....	8
53.....	DDS225-353.....	Strain Relief		2
54.....	DDS225-354AE.....	Motor Cord		1
55.....	DDS225-355.....	Front Cover		1
56.....	TS-1550031.....	Flat Washer	3/16.....	26
58.....	DDS225-358.....	Screw	3/16-24 x 3/8.....	14
59.....	DDS225-359.....	Rear Cover.....		1
60.....	DDS225-360.....	Self Tapping Screw.....	1/4 x 1/2.....	2
61.....	TS-069204.....	Flat Washer	SAE #10.....	2
62.....	DDS225-362.....	Lock Piece		2
63.....	DDS225-363.....	Plastic Nut.....		2
64.....	DDS225-364.....	Lock Housing		2
65.....	DDS225-365.....	Lock Knob		2
66.....	DDS225-366.....	Scoket Head Cap Screw.....	1/4-20x 1/2.....	4
67.....	TS-0720071.....	Lock Washer.....	1/4.....	4
68.....	DDS225-368.....	Holder		2
69.....	DDS225-369.....	Plate		1
70.....	TS-1490111.....	Hex Cap Screw	M8 x 60.....	2
71.....	DDS225-371.....	Flat Washer	M8.....	4
72.....	DDS225-372.....	Spring.....		2
73.....	TS-1540061.....	Hex Nut	M8.....	2
74.....	TS-081F022.....	Phillips Pan Head Machine Screw	1/4-20 x 5/16.....	4
75.....	DDS225-375.....	Screw	3/16-24 x 1-1/4	2
76.....	DDS225-376.....	Limit Switch.....		1
77.....	DDS225-377.....	Cord Holder.....		2
78.....	DDS225-378AEA.....	Cord, Limit Switch		1
79.....	DDS225-379AE.....	Switch Cord, Mag Switch to Power Switch		1
81.....	DDS225-381AE.....	Switch Cover		1
82.....	DDS225-382AE.....	Power Switch		1
83.....	DDS225-383AE.....	Switch Bracket		1
84.....	DDS225-384.....	Top Cover Warning Label (Not Shown).....		1
85.....	DDS225-385.....	JET Logo		1
86.....	DDS225-386.....	I.D. Label.....		1
87.....	TS-0720081.....	Lock Washer.....	5/16	1
88.....	DDS225-388.....	Table Warning Label (Not Shown).....		2
89.....	DDS225-389.....	Plug for Power Cord.....		1
90.....	DDS225-390.....	Running Direction Label (Not Shown).....		1
91.....	DDS225-391.....	Switch Lock.....		1
92.....	DDS225-392.....	Pad.....		4
93.....	DDS225-393.....	Cord, Limit Switch		1
94.....	TS-1540021.....	Hex Nut	M4.....	4
95.....	TS-1550021.....	Flat Washer	M4.....	6
96.....	DDS225-396.....	Screw	M4x12.....	4
97.....	DDS225-397.....	Safety Key Support Bracket.....		1
98.....	DDS225-398.....	Screw	M4x30.....	2
99.....	DDS225-399.....	Limit Switch.....		1
100.....	DDS225-3100.....	Strain Relief		2
.....	DDS225-SKWC.....	Safety Key w/Chain (including, #101, #102) ...		1
101.....	DDS225-3101.....	Safety Key.....		1
102.....	DDS225-3102.....	Chain.....		1
103.....	DDS225-3103.....	Strain Relief		1

DDS-225 Motor & Cabinet Assembly

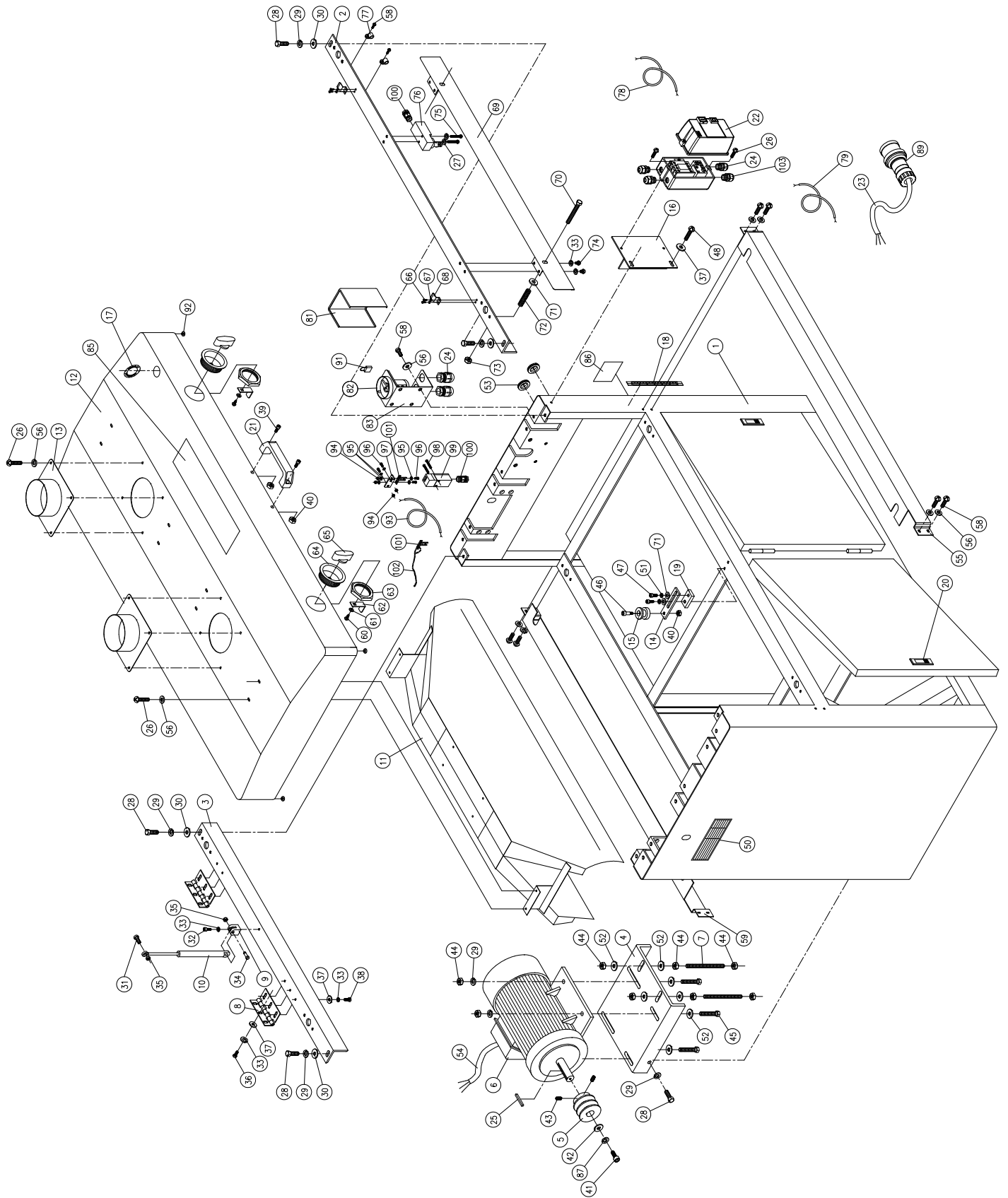

DDS-225 Gearbox Assembly

Index No.	Part No.	Description	Size	Qty.
	DDS225-GBA	Complete Gearbox Assembly w/Motor	400V	1
	DDS225-401CGA	Complete Gearbox Assembly wo/Motor		1
1	DDS225-401A	Gearbox Body		1
2	TS-0720071	Lock Washer	1/4	4
3	TS-0207071	Socket Head Cap Screw	1/4-20 x 1-1/4	4
4	DDS225-404	Drain Plug		1
5	BB-626VV	Ball Bearing		2
6	DDS225-406	Gear	66T	1
7	DDS225-407	Key	4 x 4 x 8	1
8	DDS225-408	Pinion		1
9	BB-6000VV	Ball Bearing	6000VV	1
10	DDS225-410	C-Ring		1
11	DDS225-411	Gear	70T	1
12	DDS225-412	Gear	57T	1
13	DDS225-413	Shaft		1
14	BB-6002VV	Ball Bearing	6002VV	2
15	DDS225-415	Key	5 x 5 x 20	1
16	DDS225-416	Shaft		1
17	DDS225-417	Cover		1
18	TS-1503041	Socket Head Cap Screw	M6 x 16	8
19	DDS225-419	Key	5 x 5 x 30	1
20	DDS225-420	Collar		1
21	DDS225-421	Oil Plug		1
22	DDS225-422	Handle		1
23	BB-6006VV	Ball Bearing		1
27	DDS225-427	Block		1
29	DDS225-429A	Gear Assembly	64T / 77T	1
30	DDS225-430	Key	6 x 6 x 50	1
31	DDS225-431AE	Cable		1
32	DDS225-432AE	Motor (Not available separately)	1/4HP, 3PH, 400V	1
33	DDS225-433	Gasket		2
34	DDS225-434	Steel Ball		1
35	DDS225-435	Spring		1
36	TS-1523011	Socket Set Screw	M6 x 6	1
37	DDS225-234AE	Strain Relief		1
	DDS225-GG	Gearbox Gasket (not shown)		1
		Gearbox Oil	SAE90	0.7Liter

* NOTE: change gearbox oil every 2,500 operating hours (gearbox oil, SAE90, 0.7 liter)

DDS-225 Gearbox Assembly

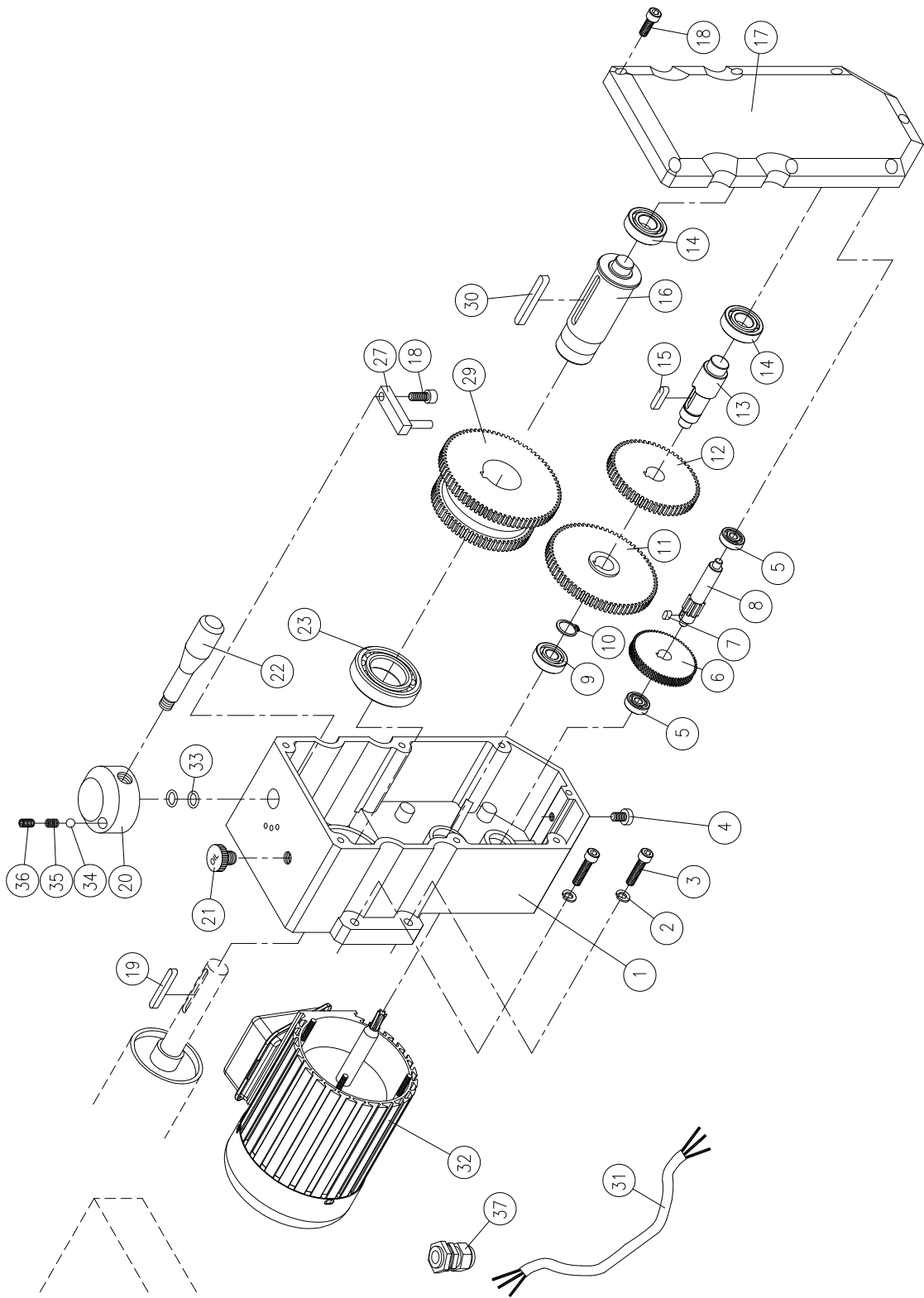

DDS-225 DRO Assembly

Index No.	Part No.	Description	Size	Qty.
.....	DDS225-DROA	Digital Readout Assembly (Includes index #1 ~ #10)		1
1.....	TS-0680011	Flat Washer	3/16	4
2.....	DDS225-502	Screw	3/16-24x5/16	4
3.....	15S-314	Digital Readout		1
4.....	DDS225-504	Flat Head Machined Screw	M3x.05Px5	2
5.....	DDS225-505A	Bracket		1
6.....	TS-0680021	Flat Washer	1/4	2
7.....	TS-0207021	Socket Head Cap Scre	1/4-20x1/2	2
8.....	15S-600	Battery	1.5 Volt	1
9.....	DDS225-509	Lower Bracket		1
10.....	DDS225-510	Upper Bracket		1

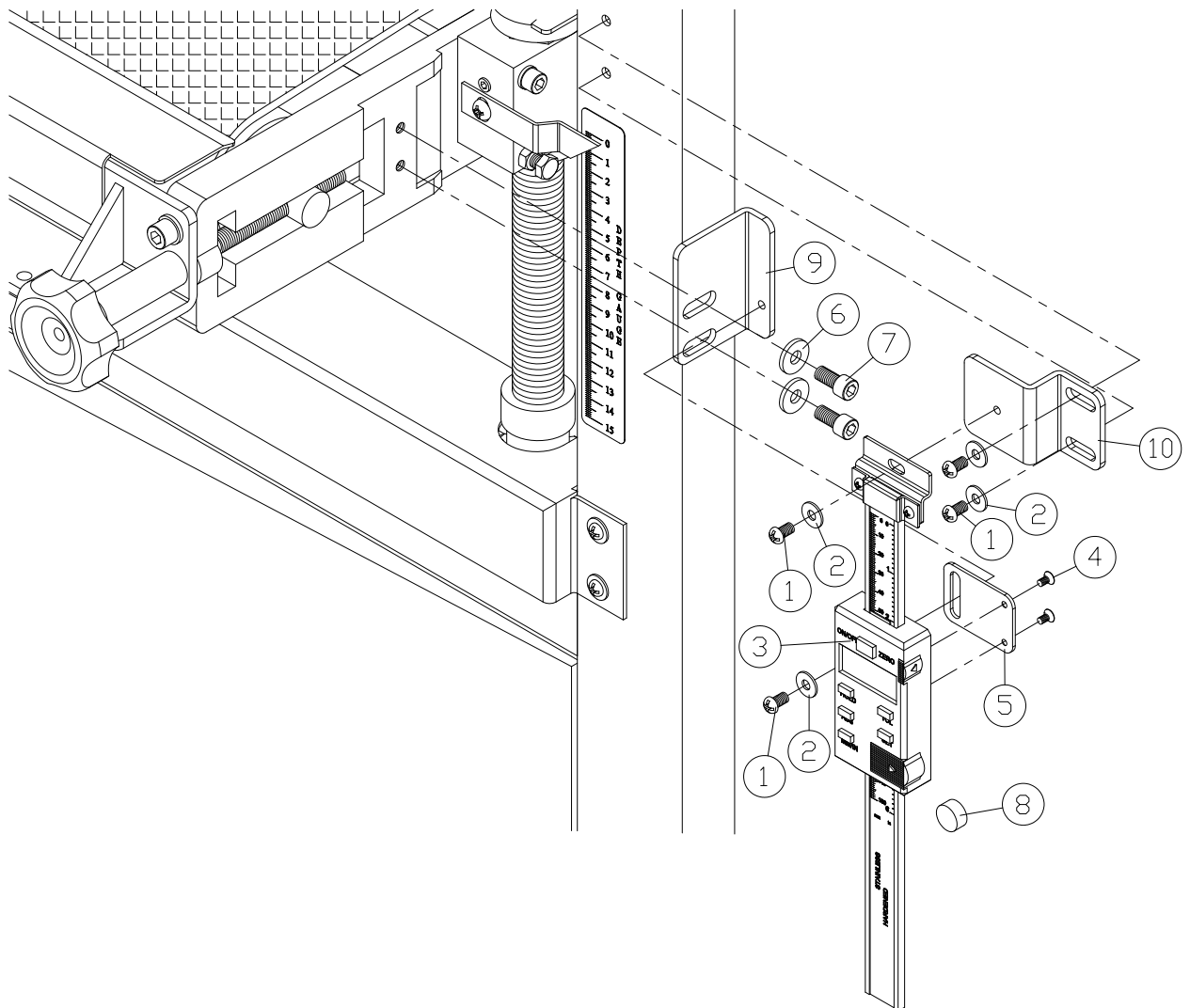

DDS-225.....1791290T.....3~400V, 50Hz

	colour of strands	Litzenfarben	couleur des cordons
BK	black	schwarz	noir
WH	white	weiß	blanc
BU	blue	blau	bleu
YE	yellow	gelb	jaune
RD	red	rot	rouge
BN	brown	braun	brun
GY	grey	grau	gris
GNYE	green-yellow	grün-gelb	vert-jaune
OG	orange	orange	orange
VT	violet	violett	violet

	meaning of symbol	Bedeutung der Zeichen	interprétation
M	motor	Motor	moteur
S	switch	Schalter	interrupteur
C	condenser	Kondensator	condensateur
E	electronic unit	Elektronik Einheit	unité électronique
F	fuse	Sicherung	fusible
RS	reversing switch	Drehrichtungsschalter	commu. droite/gauche
CS	centrifugal switch	Fliehkraftschalter	déclencheur centrifuge
OL	overload cut-off	Überlastschutzschalter	déclencheur surcharge
LS	limit switch	Positionsendschalter	micro

