

# GB - ENGLISH

## Operating Instructions

Dear Customer,

Many thanks for the confidence you have shown in us with the purchase of your new JET-machine. This manual has been prepared for the owner and operators of a JET JWP-12 planer to promote safety during installation, operation and maintenance procedures. Please read and understand the information contained in these operating instructions and the accompanying documents. To obtain maximum life and efficiency from your machine, and to use it safely, read this manual thoroughly and follow instructions carefully.

### ...Table of Contents

#### 1. Declaration of conformity

#### 2. JET Warranty

#### 3. Safety

Authorized use  
General safety notes  
Remaining hazards

#### 4. Machine specifications

Technical data  
Noise emission  
Contents of delivery  
Description of machine

#### 5. Transport and start up

Transport and installation  
Assembly  
Mains connection  
Dust connection  
Starting operation

#### 6. Machine operation

#### 7. Changing the knives

#### 8. Maintenance and adjustment

#### 9. Troubleshooting

#### 10. Available accessories

### 1. Declaration of conformity

On our own responsibility we hereby declare that this product complies with the regulations\* listed on page 2. Designed in consideration with the standards\*\*. CE type examination\*\*\* conducted by\*\*\*\*

### 2. JET Group Warranty

The JET Group makes every effort to assure that its products meet high quality and durability standards and warrants to the original retail consumer/purchaser of our products that each product be free from defects in materials and workmanship as follows:

2 YEARS ON ALL MECHANICAL PARTS

1 YEAR ON ALL ELECTRICAL PARTS:

This Warranty does not apply to defects due to directly or indirectly misuse, abuse, negligence or accidents, normal wear-and-tear, repair or alterations outside our facilities, or to a lack of maintenance.

The Jet group limits all implied warranties to the period specified above, from the date the product was purchased at retail.

To take advantage of this warranty, the product or part must be returned for examination, postage prepaid, to an authorized repair station designated by our office.

Proof of purchase date and an explanation of the complaint must accompany the merchandise.

If our inspection discloses a defect, we will either repair or replace the product, or refund the purchase price if we cannot readily and quickly provide a repair or replacement, if you are willing to accept a refund.

We will return repaired product or replacement at JET'S expense, but if it is determined there is no defect, or that the defect resulted from causes not within the scope of JET'S warranty, then the user must bear the cost of storing and returning the product.

The JET Group reserves the right to make alterations to parts, fittings, and accessory equipment which they may deem necessary for any reason whatsoever.

### 3. Safety

### 3.1 Authorized use

This machine is designed for planing wood and wood derived materials. Machining of other materials is not permitted and may be carried out in specific cases only after consulting with the manufacturer.

The proper use also includes compliance with the operating and maintenance instructions given in this manual. The machine must be operated only by persons familiar with its operation, maintenance and repair and who are familiar with its hazards. The required minimum age must be observed

The machine must only be used in a technically perfect condition

When working on the machine, all safety mechanisms and covers must be mounted.

In addition to the safety requirements contained in this operating instructions and your country's applicable regulations, you should observe the generally recognized technical rules concerning the operation of woodworking machines.

Any other use exceeds authorization. In the event of unauthorized use of the machine, the manufacturer renounces all liability and the responsibility is transferred exclusively to the operator.

### 3.2 General safety notes

Woodworking machines can be dangerous if not used properly. Therefore the appropriate general technical rules as well as the following notes must be observed.



Read and understand the entire instruction manual before attempting assembly or operation.

Keep this operating instruction close by the machine, protected from dirt and humidity, and pass it over to the new owner if you part with the tool.

No changes to the machine may be made.

Daily inspect the function and existence of the safety appliances before you start the machine.

Do not attempt operation in this case, protect the machine by unplugging the mains cord.

Remove all loose clothing and confine long hair.

Before operating the machine, remove tie, rings, watches, other jewellery, and roll up sleeves above the elbows.

Wear safety shoes; never wear leisure shoes or sandals.

Always wear the approved working outfit

Do **not** wear gloves while operating this machine.

Control the stopping time of the machine, it may not be longer than 10 seconds.

Remove cut and jammed workpieces only when motor is turned off and the machine is at a complete standstill.

Install the machine so that there is sufficient space for safe operation and workpiece handling.

Keep work area well lighted.

The machine is designed to operate in closed rooms and must be placed stable on firm and levelled ground.

Make sure that the power cable does not impede work and cause people to trip.

Keep the floor around the machine clean and free of scrap material, oil and grease.

Stay alert!

Give your work undivided attention. Use common sense. Do not operate the machine when you are tired.

Do not operate the machine under the influence of drugs, alcohol or any medication. Be aware that medication can change your behaviour.

Never reach into the machine while it is operating or running down.

Never leave a running machine unattended. Before you leave the workplace switch off the machine.

Keep children and visitors a safe distance from the work area.

Do not operate the electric tool near inflammable liquids or gases. Observe the fire fighting and fire alert options, for example the fire extinguisher operation and place.

Do not use the machine in a dump environment and do not expose it to rain.

Wood dust is explosive and can also represent a risk to health.

Dust from some tropical woods in particular, and from hardwoods like beach and oak, is classified as a carcinogenic substance.

Always use a suitable dust extraction device

Before machining, remove any nails and other foreign bodies from the workpiece.

Never operate with the guards not in place – serious risk of injury!

All anti-kickback fingers must automatically return to their rest position (downwards)

Never reach with your hands into the machine when guiding or sorting the workpiece.

Use a feeding aid (push wood) if you want to feed short stock into the machine. Stock must have a minimum length of 250mm.

Specifications regarding the maximum or minimum size of the workpiece must be observed.

Do not remove chips and workpiece parts until the machine is at a complete standstill.

Always use sharp cutter knives.

Do not machine more than two workpieces at the same time.

To plane stock which surfaces are not parallel, use suitable feeding aids (make fitting templates).

Use roller supports on both sides of the planer when working long stock.

Keep planer bed surface clean, in particular remove resin residue.

Connection and repair work on the electrical installation may be carried out by a qualified electrician only.

Have a damaged or worn cord replaced immediately.

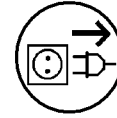

Make all machine adjustments or maintenance with the machine unplugged from the power source.

### 3.3 Remaining hazards

When using the machine according to regulations some remaining hazards may still exist

Touching the cutter block in the machining area can cause injury.

Drawing-in/trapping hazard by power feed mechanism.

Squeezing hazard by workpiece power-outfeed.

Thrown workpiece parts can lead to injury

Sawdust and noise can be health hazards. Be sure to wear personal protection gear such as safety goggles and ear protection. Use a suitable dust exhaust system.

The use of incorrect mains supply or a damaged power cord can lead to injuries caused by electricity.

## 4. Machine specifications

### 4.1 Technical data

Planing width	max 318 mm
Planing thickness	6 to 153 mm
Depth of cut	max. 2,5 mm
Number of knives	2
Cutterhead diameter	48 mm
No-load speed $n_0$	9000 rpm
Cuts per minute	18000
Cutter knife length	319mm
Cutter knife width	18mm
Cutter knife thickness	3mm
Feed rate	7 m/min
Weight	27 kg

Mains	230V ~1L/N/PE	50-60Hz
Motor input power		2000W
Reference current		9 A
Extension cord	H05W-F	3G1mm <sup>2</sup>
Installation fuse protection		16A

### 4.2 Noise emission

Determined according to EN 1807:1999 (Inspection tolerance 4 dB)

Acoustic power level (acc. EN 3746):  
Idling 101,5 dB (A)

Acoustic pressure level (EN 11202):  
Idling 88,7 dB (A)

The specified values are emission levels and are not necessarily to be seen as safe operating levels. This information is intended to allow the user to make a better estimation of the hazards and risks involved.

### 4.3 Content of delivery

Planer  
Dust chute 100mm  
Thickness crank  
Knife setting gauge  
4 Rubber feet  
Assembly kit  
Operating manual  
Spare parts list

### 4.4 Description of machine

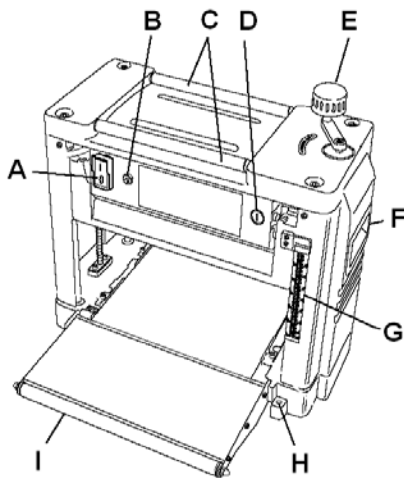

Fig 1

A....ON/OFF Switch  
B....Overload cut-off  
C....Transport rollers  
D....Motor brushes  
E....Thickness crank  
F....Carrying handles  
G....Thickness scale  
H....Mounting holes  
I....Support infeed roller

## 5. Transport and start up

### 5.1 Transport and installation

The machine is designed to operate in closed rooms and must be placed stable on firm and levelled ground.

The machine can be bolted down if required.

Fold the infeed and outfeed rollers up when the planer is not in use and during storing.

Wrap the power cord around the hangers under the infeed table(Fig2)

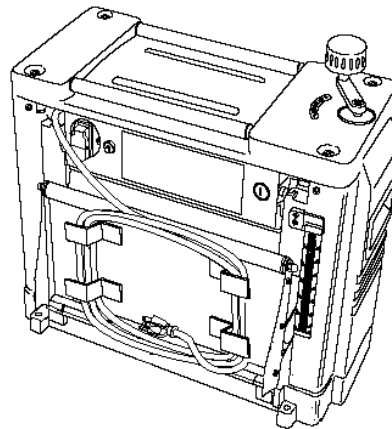

Fig 2

For packing reasons the machine is not completely assembled.

### 5.2 Assembly

If you notice any transport damage while unpacking, notify your supplier immediately. Do not operate the machine!

Dispose of the packing in an environmentally friendly manner.

Clean all rust protected surfaces with a mild solvent.

Install rubber feet (J) and Thickness crank (B).

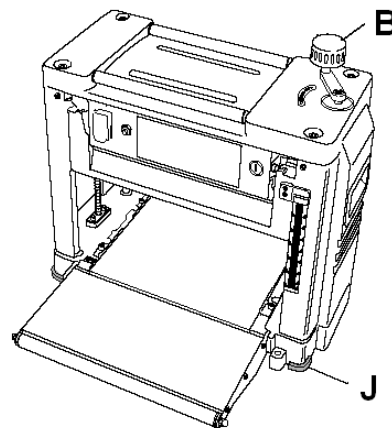

Fig 3

### 5.3 Mains connection

Mains connection and any extension cords used must comply with applicable regulations.

The mains voltage must comply with the information on the machine licence plate.

The mains connection must have a 16 A surge-proof fuse.

Only use connection cables marked H05VV-F

Connections and repairs to the electrical equipment may only be carried out by qualified electricians.

### 5.4 Dust connection

Before initial operation, the machine must be connected to a dust extractor.

### 5.5 Starting operation

You can start and stop the machine with the ON/OFF-button(A).

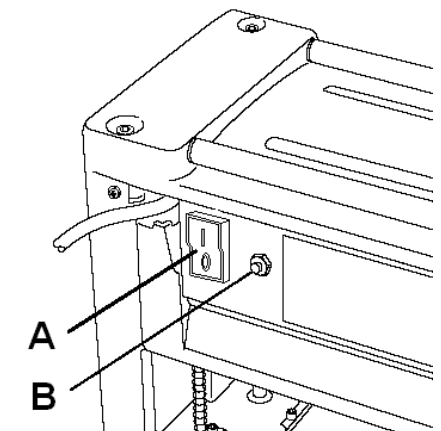

Fig 4

In case of machine overload the motor overload cut-off (B) will react. After appr.5 min of cooling the overload cut off can be reset.

**Attention: The machine will start when you reset the overload push button!**

## 6. Machine operation

### Correct operating position:

To feed the workpiece into the machine, position yourselves offset to one side of the feed opening.

### Workpiece handling:

Adjust the planer table to the workpiece thickness.

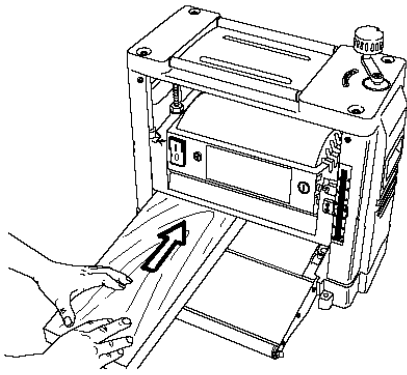

**Fig 5**

Feed workpiece slowly and straight into the thicknesser. It will then be automatically fed through the thicknesser.  
 Guide workpiece straight through the thicknesser.  
 To remove the workpiece from the machine, position yourselves offset to one side of the outfeed opening.

Support long workpieces with helping roller stands.

**Operating notes:**

Always use sharp cutter knives!

Feed with thicker workpiece end at the front, hollow side downward.

Max. 2,5mm depth of cut.

If a workpiece gets stuck raise the cutterhead by app. 1mm (1 crank turn).

Plane the stock with the grain, if possible (Fig 6).

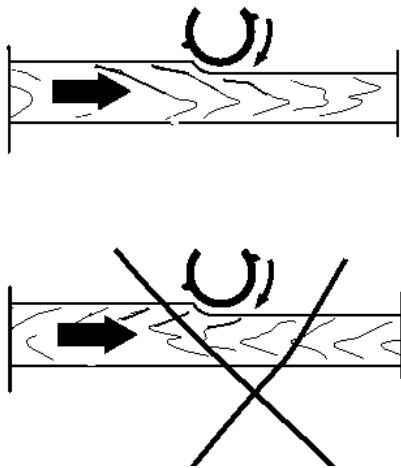

**Fig 6**

You get a better surface when planing several passes with less chip removal.

Switch machine off if no further planning is to be done immediately afterwards.

Workpieces shorter than 250mm may not be processed.

Machine max. 2 workpieces at one time. Feed on both outer sides.

**7. Changing cutter knives**

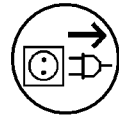

The cutter knives may only be changed when the mains plug is pulled!

Risk of personal injury by cuts from the cutter knives. Wear suitable gloves when changing cutter knives.

**Knife removal:**

Raise the cutterhead to its highest position.

Remove the thickness crank (E) and the planer cover screws(K).

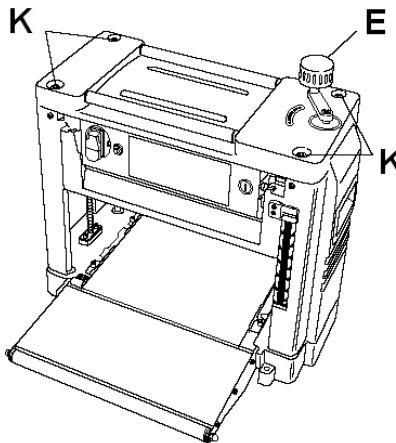

**Fig 7**

Remove the planer cover.

Remove the cutter block cover (L)

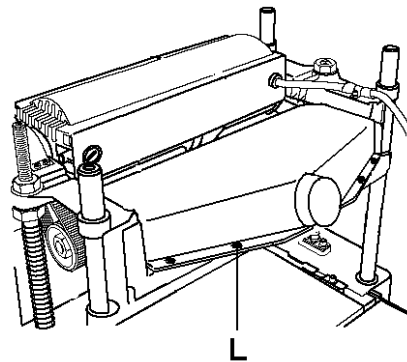

**Fig 8**

Turn the hex-head bolts (M) of the cutter knife lock bar all the way in (wear gloves!).

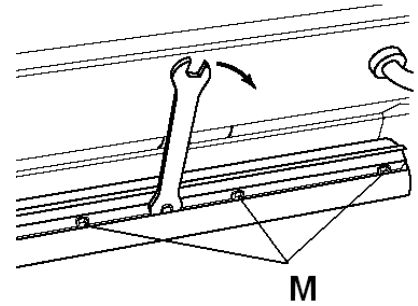

**Fig 9**

At first remove cutter knife, then cutter knife lock bar from the cutter block.

Clean all surfaces of cutter block and cutter knife lock bar with a suitable solvent (do not use cleaning agents that could corrode the light metal components).

**Knife installation:**

Use only suitable cutter knives conforming the technical specification and EN 847-1

Unsuitable, incorrectly mounted, dull, cracked or bent cutter knives can work loose or increase the risk of kickback considerably.

Always replace both cutter knives at once.

The cutter knife lock bars are balanced to each other and thus can randomly be placed.

Only cutter knives marked "HSS" or "HS" can be resharpened! When resharpening, remove the same amount of material from both cutter knives, otherwise a balancing error may cause damage to the bearings.

Cutter knives can only be resharpened down to a minimum width of 14 mm.

Use genuine Jet replacement parts only.

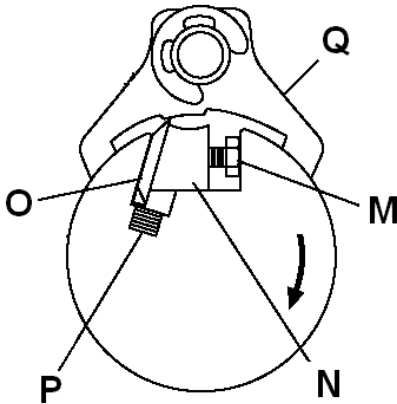

**Fig 10**

Place the cutter knife lockbar (N) in the cutterblock's groove.

Make sure the springs (P) are in place. Turn the hex-head bolts so far that the cutter knife will just slide in.

Insert a sharp cutter knife (O) and adjust position with the cutter knife lockbar, so that neither protrudes over the edge of the cutter block.

Use the knife setting gauge (Q) to adjust the knife.

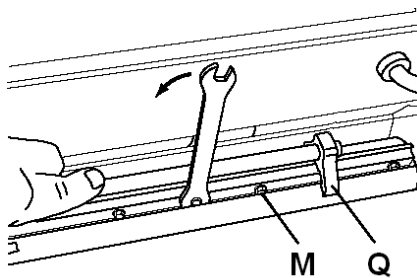

**Fig 11**

To tighten the cutter knife, turn the hex-head bolts (M) of the cutter knife lockbar.

Start tightening with the two outer bolts. Do not extend tool when tightening the bolts, do not tighten bolts by striking the wrench.

Install the cutter block cover, planer cover and adjustment crank after knife changing has been completed.

Connect to the dust extraction system.

## 8. Maintenance and inspection

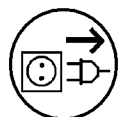

Make all machine adjustments or maintenance with the machine unplugged from the power source.

Clean the machine regularly

Inspect the proper function of the dust extraction daily.

Defective safety devices must be replaced immediately.

Before starting any work, check the mobility of the anti-kickback fingers (must fall down by their own weight).

### Changing of brushes:

Disconnect from power source, unplug!

Inspect the brushes after 50 hours of use.

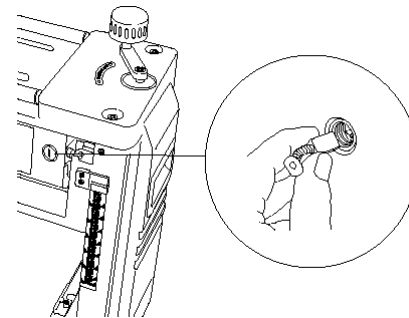

**Fig 12**

If the brushes are worn to 3mm replace them.

(Jet Article No: JWP12-096...2 pcs needed)

## 9. Trouble shooting

Carry out maintenance, cleaning and repair work only when the motor is switched off and machine has come to a full stop. Pull the mains plug. All protective and safety devices must be re-attached immediately after completed cleaning, repair and maintenance work.

Repair and maintenance work on the electrical system may only be carried out by a qualified electrician.

### Motor doesn't start

\*No electricity-  
check mains and fuse.

\*Defective switch, motor or cord-  
consult an electrician.

\*Overload has reacted-  
Wait 5 minutes, push overload button and start again.

### Machine vibrates excessively

\*Stand on uneven floor-  
adjust stand for even support.

\*knives of different seize-  
all knives must have same width.

\*damaged knife-  
replace knives set immediately

### Cutting surfaces is bad

\*dull knives-  
sharpen knives

\*Cutter knives blocked by chips-  
remove chips.

\*Too heavy a cut-  
make several passes.

\*knives cutting against grain-  
plane workpiece in opposite direction.

\*workpiece inhomogeneous  
\*Moisture content too high

### Snipe

\*Inadequate support of long boards-  
use extension roller.

\*dull knives-  
sharpen knives.

### Unparallel side to side

\*knife projection not uniform-  
adjust knives with setting gauge.

### Workpiece jams

\*Too much material removed in one pass-  
make several passes.

### Cutterhead difficult to adjust

\*Lack of lubrication-  
lubricate corner posts and screws.

### Poor workpiece feeding

\*motor belt slipping-  
tighten or replace belt.

\*Resin build up on planer bed-  
clean and wax planer bed.

\*surface of feed rollers too smooth-  
lightly roughen with sandpaper.

## 10. Available accessories

### Stock number 10000841

Set of 2 high speed steel (HSS) reversible knives

### Stock number 10000842

Open machine stand

### Stock number 708495

Helping roller stand