



JWL-1221

Wood Lathe

JWL-1221...719115M...1~230V,50Hz

PARTS LIST

TOOL FRANCE SARL
9 Rue des Pyrénées
91090 Lisses
France



www.jettools.com

P-719115M 2019 - 02

JWL-1221 Bed Assembly – Exploded View

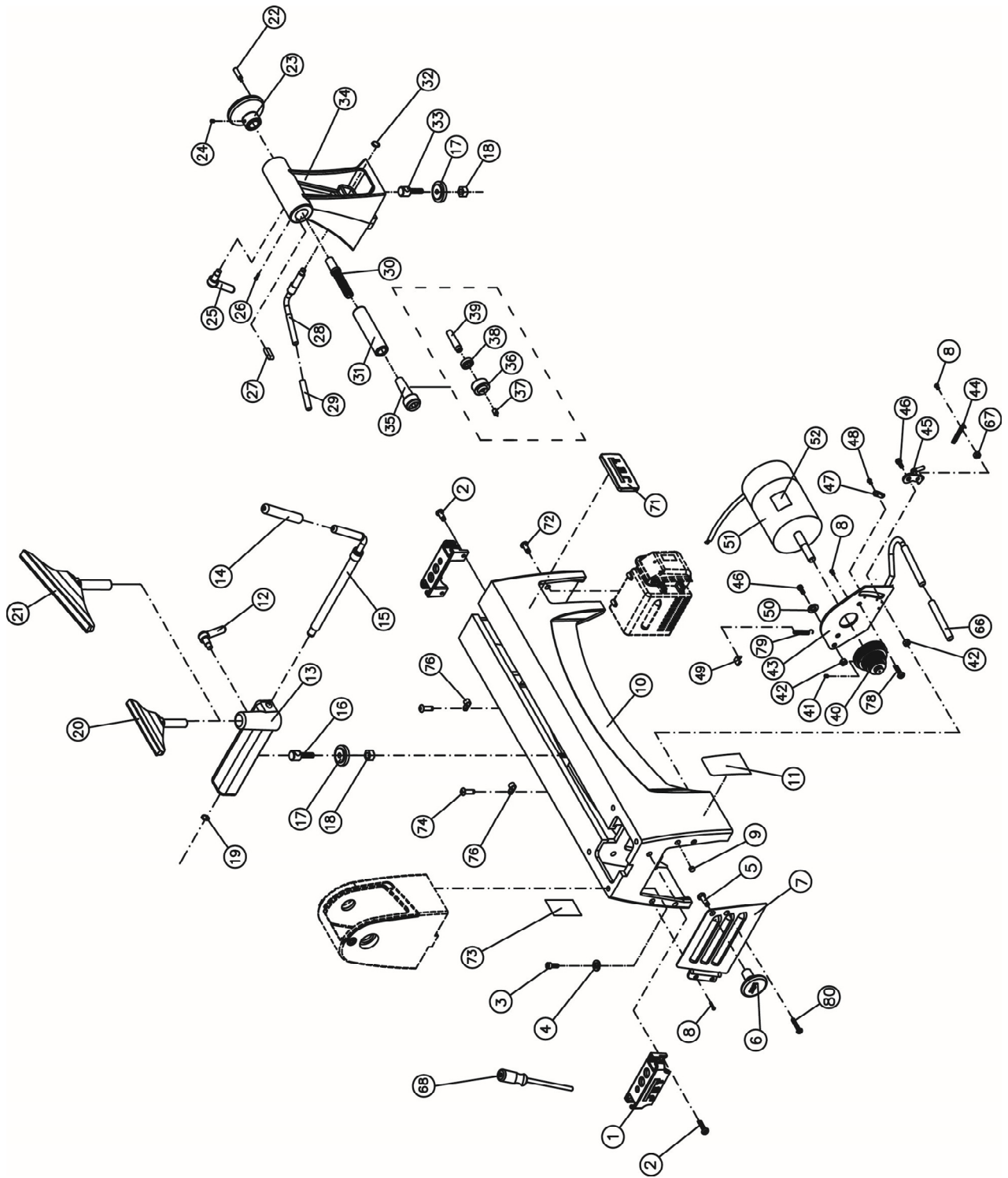

JWL-1221 Bed Assembly – Parts List

Index No	Part No	Description	Size	Qty
1	JWL1221VS-201	Tool Caddy		2
2	TS-0255021	Socket Head Button Screw	5/16"-18x1/2"	4
3	TS-0207071	Socket Head Cap Screw	1/4"-20x1-1/4"	4
4	TS-0720071	Lock Washer	1/4"	4
5	TS-1490021	Hex Cap Screw	M8x16	1
6	6295717	Knob		1
7	JWL1221VS-207	Motor Pulley Access Door		1
8	TS-081C022	Pan Head Screw	#10-24X3/8"	3
9	JWL1221VS-209	Magnet		1
10	JWL1221VS-210	Bed		1
11	6294773P	Warning Label		1
	JWL1221VS-TBA	Toolrest Base Assembly (includes #12 thru #19)		1
12	JML-59A	Lock Handle Assembly	5/16"-18x5/8"	1
13	JWL1221VS-213	Toolrest Base		1
14	JWL1221VS-214	Rubber Cover		1
15	JWL1221VS-215	Eccentric Rod		1
16	JWL1221VS-216	Toolrest Clamp Bolt		1
17	JML-44	Clamp		2
18	JML-81	Hex Nut		2
19	JML-49	C-Ring	STW-12	1
20	JWL1220-142	Toolrest	6"	1
21	JWL1220-142A	Toolrest	10"	1
	JWL1221VS-TA	Tailstock Assembly (includes # 17, 18, 22 thru #34)		1
	JWL1221VS-THA	Tailstock Handwheel Assembly (includes #22 thru #24)		1
22	JWL1221VS-222	Handle		1
23	JWL1221VS-223	Handwheel		1
24	TS-0267021	Set Screw	1/4"-20x1/4"	2
25	JML-45A	Lock Handle Assembly, Tailstock	5/16"-18x3/4"	1
26	JWL1221VS-115	Socket Head Button Screw	#10-32x5/8"	1
27	JWL1221VS-227	Key		1
28	JML-58	Eccentric Rod, Tailstock		1
29	JWL1221VS-229	Rubber Cover		1
30	JWL1221VS-230	Lead Screw		1
31	JWL1221VS-231	Quill		1
32	JML-63	C-Ring	STW-10	1
33	JWL1221VS-233	Tailstock Clamp Bolt		1
34	JWL1221VS-234	Tailstock		1
35	708331	Live Center Assembly (includes #36 thru #39)		1
36	JML-52	Live Center Head		1
37	JML-52A	Center Point for Live Center		1
38	BB-6002ZZ	Ball Bearing	6002ZZ	1
39	JML-54	Live Center Shaft		1
40	JWL1221SP-240	Motor Pulley	6-step	1
41	6295796	Nylon Insert Socket Set Screw	1/4"-20x3/8"	2
42	TS-0640081	Nylon Nut	5/16"-18	2
43	JWL1221SP-243	Motor Plate		1
44	JWL1221VS-244	Spring	69L	1
45	JWL1221VS-245	Ratchet Key		1
46	TS-0051061	Hex Cap Screw	5/16"-18x1-1/4"	2
47	JWL1221VS-247	Rack		1
48	TS-081C011	Pan Head Screw	#10-24x1/4"	2
49	JWL1221VS-249	Hook		1
50	TS-0680031	Flat Washer	5/16"	1
51	JWL1221SP-251E	Motor	3/4HP 1PH 230V	1
52	JWL1221SP-252E	Motor Label		1
	JWL1221SP-251MF	Motor Fan		1
	JWL1221SP-251MFC	Motor Fan Cover		1
	JWL1221SP-251RCE	Running Capacitor	10mF 400VAC	1
	JWL1221SP-251RCC	Running Capacitor Cover		1

Index No	Part No	Description	Size	Qty
66	JWL1221VS-266	Rubber Cover		1
67	TS-0560071	Hex Nut	#10-24	1
68	JML-11	Knockout Rod		1
71	JET-92	JET Logo with 3M Adhesive	92x38mm	1
72	TS-081C072	Pan Head Screw	#10-24x1-14"	2
73	JWL1221SP-273E	ID Label		1
74	TS-0253031	Socket Head Button Screw	#10-24x1/2"	2
76	JWL1221VS-276	Clamp	1/2"	2
78	TS-0254021	Socket Head Button Screw	1/4-20 x 1/2"	2
79	JWL1221SP-279	Spring	48L	1
80	TS-081C022	Pan Head Screw	#10-24x3/8"	1

JWL-1221 Headstock Assembly – Exploded View

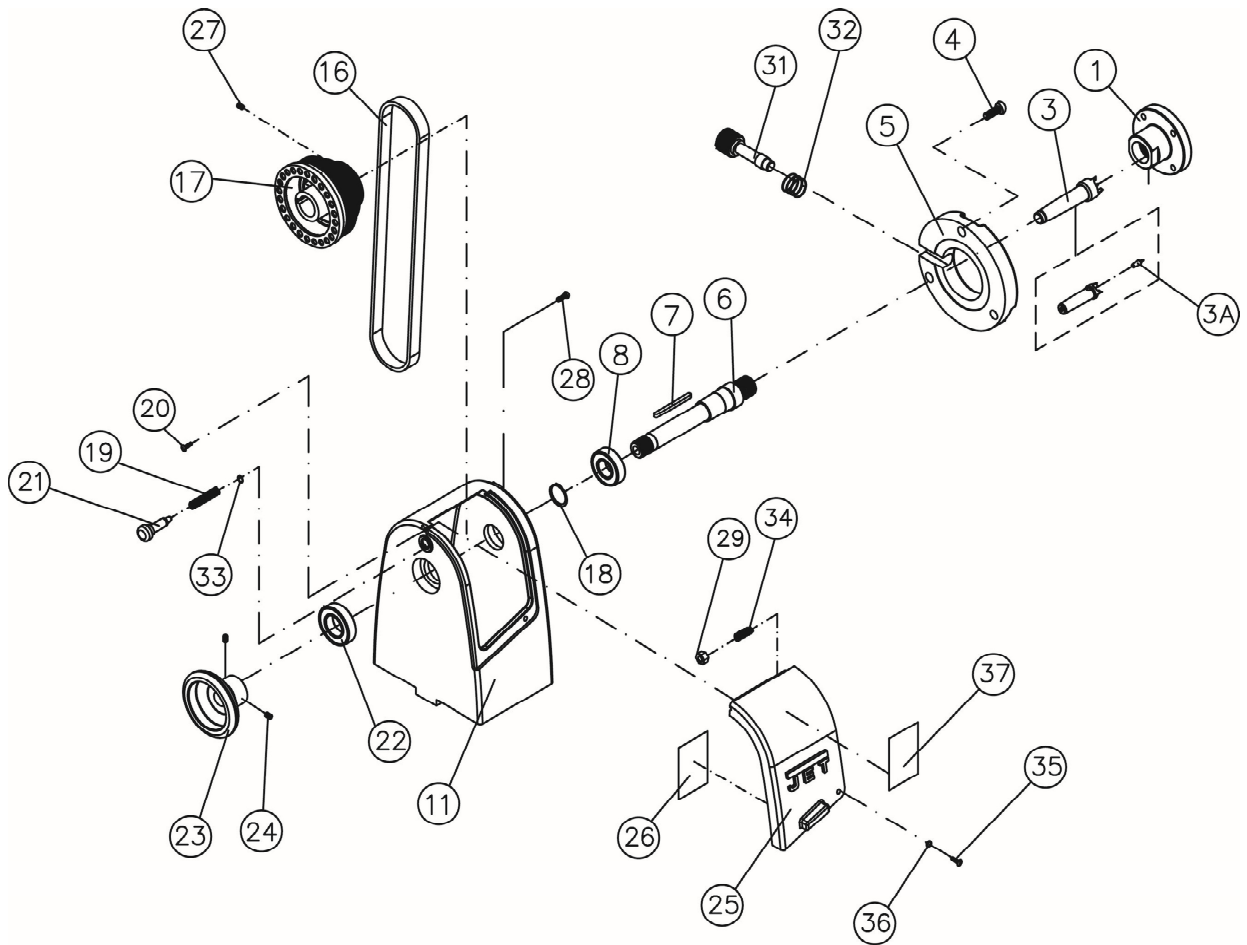

JWL-1221 Headstock Assembly – Parts List

Index No	Part No	Description	Size	Qty
.....	JWL1221SP-HAE.....	Headstock Assembly (includes #4 thru #34)	1
1	6294736E.....	Faceplate	3", M33.....	1
.....	6295796	Nylon Insert Socket Set Screw (not shown)	1/4-20x3/8"	2
3	JML-3	Spur Center	MT2.....	1
3A.....	JML-3A.....	Center Point for Spur Center	1
4	TS-0253031	Socket Head Button Screw.....	#10-24X1/2"	3
5	JWL1221VS-105A.....	Cover	1
6	JWL1221VS-106E.....	Spindle.....	M33.....	1
7	JML-5.....	Key.....	5x5x25mm	1
8	BB-6005VV	Ball Bearing	6005VV	1
11	JWL1221VS-111E.....	Headstock Casting	1
16	JWL1221SP-116	V-Belt.....	310J-4	1
17	JWL1221SP-117	Spindle Pulley.....	6-step.....	1
18	6295710	C-ring.....	S-25	1
19	JML1014-188	Spring	1
20	JWL1221VS-120	Pan Head Screw.....	M3x35.....	1
21	JML1014-189	Index Pin.....	1
22	BB-6004VV	Ball Bearing	6004VV	1
23	JWL1221VS-123.....	Handwheel.....	1
24	TS-0267021	Set Screw	1/4"-20x1/4"	2
25	JWL1221VS-125E.....	Pulley Access Door.....	1
26	JWL1221SP-126E.....	Speed Label	1
27	TS-0267041	Set Screw	1/4"-20x3/8"	2
28	JWL1221VS-128.....	Pan Head Screw.....	M3x50	1
29	4224B-179.....	Nylon Nut.....	M3	2
31	JWL1221VS-131A.....	Spindle Lock Pin.....	1
32	JWL1221VS-132.....	Spring	1
33	JML1014-187	C-Ring.....	STW-9.....	1
34	JWL1221VS-134	Spring	1
35	TS-081C042.....	Screw (not shown).....	#10-24x5/8"	1
36	JWL1221VS-136E.....	O-Ring (not shown).....	1
37	JWL1221VS-137E.....	Warning Label (not shown).....	1

JWL-1221 Switch Box Assembly – Exploded View

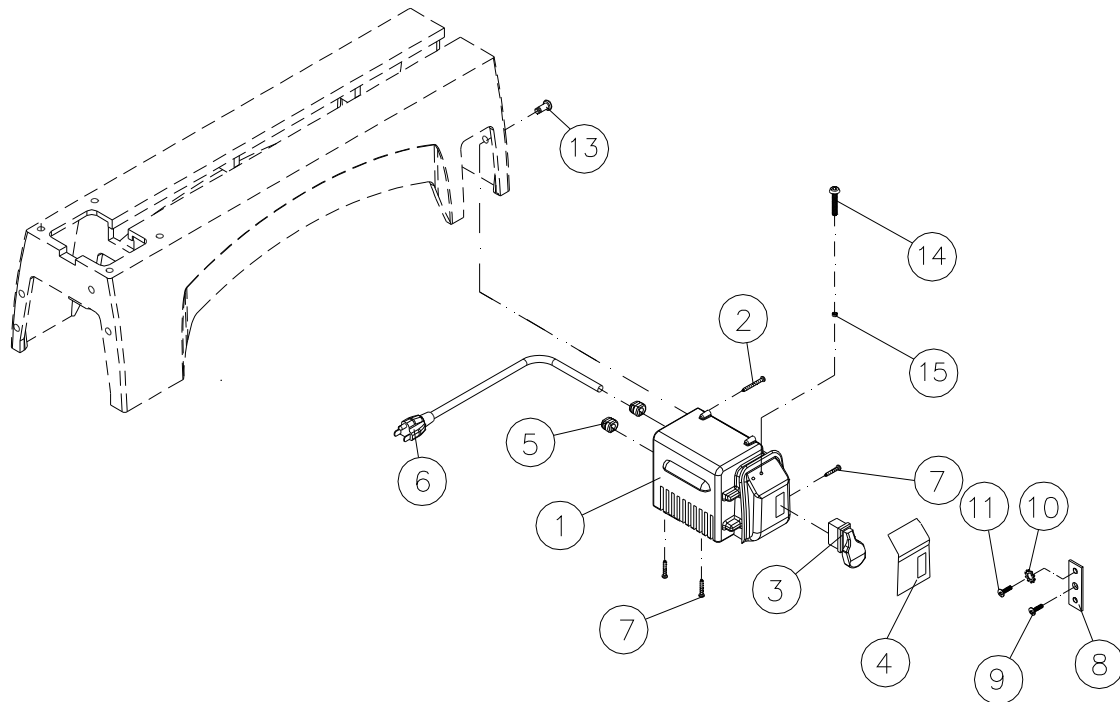

JWL-1221 Switch Box Assembly – Parts List

Index No	Part No	Description	Size	Qty
.....	JWL1221SP-SBAE	Switch Box Assembly (includes #1 thru #15)	1
1	JWL1221SP-301E	Switch Box (includes #1, 4, 14, 15)	1
2	JWL1221VS-302	Tapping Screw	M3x19mm	2
3	JML-65E	Main Switch	1
4	JWL1221SP-304E	Control Panel Label	1
5	JWL1221VS-320	Strain Relief	6P-4	2
6	JWL1015-170E	Power Cable	1
7	JWL1221SP-307	Phillips Pan Hd Tapping Screw	M3.5x 8mm	4
8	JWL1015-171	Ground Plate	1
9	JWL1015-163	Tapping Screw	M3.5x6mm	1
10	TS-073304	External Tooth Lock Washer	1/4"	2
11	TS-1533032	Pan Head Screw	M5x10	2
12	JWL1221SP-312	Dust Sheet (not shown)	2
13	TS-081C072	Pan Head Screw	#10-24x1-14"	2
14	F009669	Socket Head Button Screw	#10-24x3/8"	2
15	TS-0560071	Hex Nut	#10-24	2

JWL-1221

719115M.....1~230V, 50Hz

230/50/1

	colour of strands	Litzenfarben	couleur des cordons
BK	black	schwarz	noir
WH	white	weiß	blanc
BU	blue	blau	bleu
YE	yellow	gelb	jaune
RD	red	rot	rouge
BN	brown	braun	brun
GY	grey	grau	gris
GNYE	green-yellow	grün-gelb	vert-jaune
OG	orange	orange	orange
VT	violet	violett	violet

	meaning of symbol	Bedeutung der Zeichen	interprétation
M	motor	Motor	moteur
S	switch	Schalter	interrupteur
C	condenser	Kondensator	condensateur
E	electronic unit	Elektronik Einheit	unité électronique
F	fuse	Sicherung	fusible
RS	reversing switch	Drehrichtungsschalter	commu. droite/gauche
CS	centrifugal switch	Fliehkraftschalter	déclencheur centrifuge
OL	overload cut-off	Überlastschuttschalter	déclencheur surcharge

