

JET

JBM-5-M WOODWORKING MORTISER

JBM-5-M....708580M....1~230V, 50Hz

PARTS LIST

JPW (Tool) AG
Tämperlistrasse 5
CH-8117 Fällanden
Switzerland
Phone +41 44 806 47 48
Fax +41 44 806 47 58
www.jettools.com



P-708580M 2017-03

JBM-5-M Benchtop Mortiser

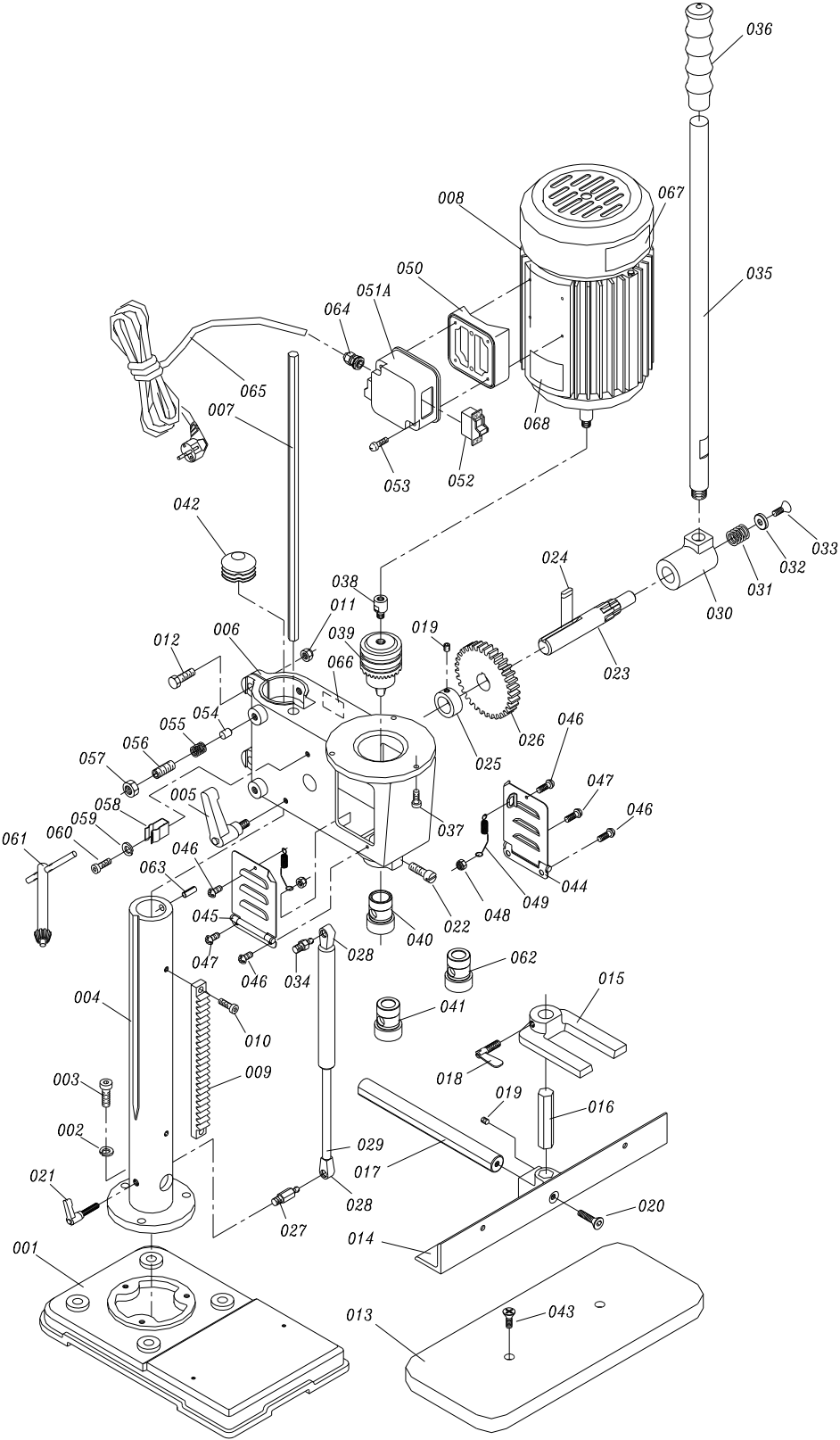

Parts List for the JBM-5-M Benchtop Mortiser (1/.2)

Index No.	Part No.	Description	Size	Qty.
1	23011045	Base		1
2	50302003	Lock Washer	5/16	3
3	50102018	Hex Socket Cap Screw	M8×1.25×20	3
4	23011002	Column		1
5	23011053	Lock Handle	M8×1.25×10	1
6	23011046	Head		1
7	23011004	Depth Stop		1
8	23011054E	Motor		1
	JBM5-RCE	Running capacitor 16MFD/350VAC (not shown)		1
9	23011005	Rack		1
10	50102032	Hex Socket Cap Screw	M6×1.0×16	2
11	50201017	Nut	M8×1.25	2
12	50102021	Hex Cap Bolt	M8×1.25×30	2
13	23011055	Table		1
	23011056A	Fence Assembly	#14,16,17,19,20	
14	23011056	Fence		1
15	23011057	Hold Down		1
16	23011058	Hold Down Post		1
17	23011059	Fence Rod		1
18	23011067	Wing Screw	M8×1.25×25	1
19	50103003	Set Screw	M6×1×6	2
20	50108005	Flat Head Screw	M6×1×22	1
21	23011009	Lock Handle	M8×1.25×30	1
22	23011010	Brass Screw	M8×1.25×25	1
23	23011068	Pinion Shaft		1
24	50604003	Key	5×5×14	1
25	23011012	Collar		1
26	23011013	Gear		1
27	23011014	Lower Cylinder Fitting		1
	23011031A	Hydraulic Cylinder Assembly	#28,29	1
28	23011030	Cylinder Head		2
29	23011031	Hydraulic Cylinder		1
30	23011062	Clutch Block		1
31	23011063	Spring		1
32	23011064	Washer		1
33	50108004	Flat Head Screw	M6×1×11	1
34	23011017	Upper Cylinder Fitting		1
35	23011065	Handle Rod		1
36	23011019	Handle Grip		1
37	50102004	Hex Socket Cap Screw	M5×0.8×16	3
38	23011020	Adapter		1
39	23011032	Chuck		1
40	23011033	Bushing	5/8	1
41	23011034	Bushing	3/4	1
42	23011021	Cap		1
43	50105005	Flat Head Screw	M6×1×20	2
44	23011066	Right Side Cover Assembly		1
45	23011067	Left Side Cover Assembly		1
46	50104007	Screw	M5×01.8×8	2
47	50102008	Screw	M5×01.8×12	2
48	50102007	Nut	M5×0.8	2

Parts List for the JBM-5-M Benchtop Mortiser (2/.2)

Index No.	Part No.	Description	Size	Qty.
49	23011068	Spring		2
50	23011050	Switch Base		1
51	23011051	Switch Cover		1
52	23011029E	Magnetic Switch		1
53	50161005	Tap Screw		2
54	23011026	Brass Pin		2
55	23011027	Spring		2
56	50103008	Set Screw	M10×1.5×20	2
57	50201004	Nut	M10×1.5	2
58	23011077	Chuck Key Holder		1
59	50322004	Lock Washer	M5	1
60	50102002	Hex Socket Cap Screw	M5×0.8×8	1
61	23011076	Chuck Key		1
62	23011085E	Bushing	13/16"	1
63	50602032	Pin	6×16L	1
64	51102004E	Strain Relief Bushing(VDE-PG110)		1
65	23011801E	Power Cord(VDE)		1
66	23010056E	I.D Label		1
67	23010045	JET Label		1
68	23010057E	Motor Label		1

JBM-5-M
708580M

1~230V, 50Hz

	colour of strands	Litzenfarben	couleur des cordons
BK	black	schwarz	noir
WH	white	weiß	blanc
BU	blue	blau	bleu
YE	yellow	gelb	jaune
RD	red	rot	rouge
BN	brown	braun	brun
GY	grey	grau	gris
GNYE	green-yellow	grün-gelb	vert-jaune
OG	orange	orange	orange
VT	violet	violett	violet

	meaning of symbol	Bedeutung der Zeichen	interprétation
M	motor	Motor	moteur
S	switch	Schalter	interrupteur
C	condenser	Kondensator	condensateur
E	electronic unit	Elektronik Einheit	unité électronique
F	fuse	Sicherung	fusible
RS	reversing switch	Drehrichtungsschalter	commu. droite/gauche
CS	centrifugal switch	Fliehkraftschalter	déclencheur centrifuge
OL	overload cut-off	Überlastschuttschalter	déclencheur surcharge
LS	limit switch	Positionsendschalter	micro

