



JPT-8B-M

Planer & Thicknesser

707400M.....1~230V, PE, 50-60Hz

**PARTS LIST
ERSATZTEILLISTE
LISTE DE PIECES**



TOOL FRANCE SARL

9 Rue des Pyrénées, 91090 LISSES, France

www.jettools.com

P- 707400M

2019-03

Parts Breakdown for JPT-8B-M Planer & Thicknesser

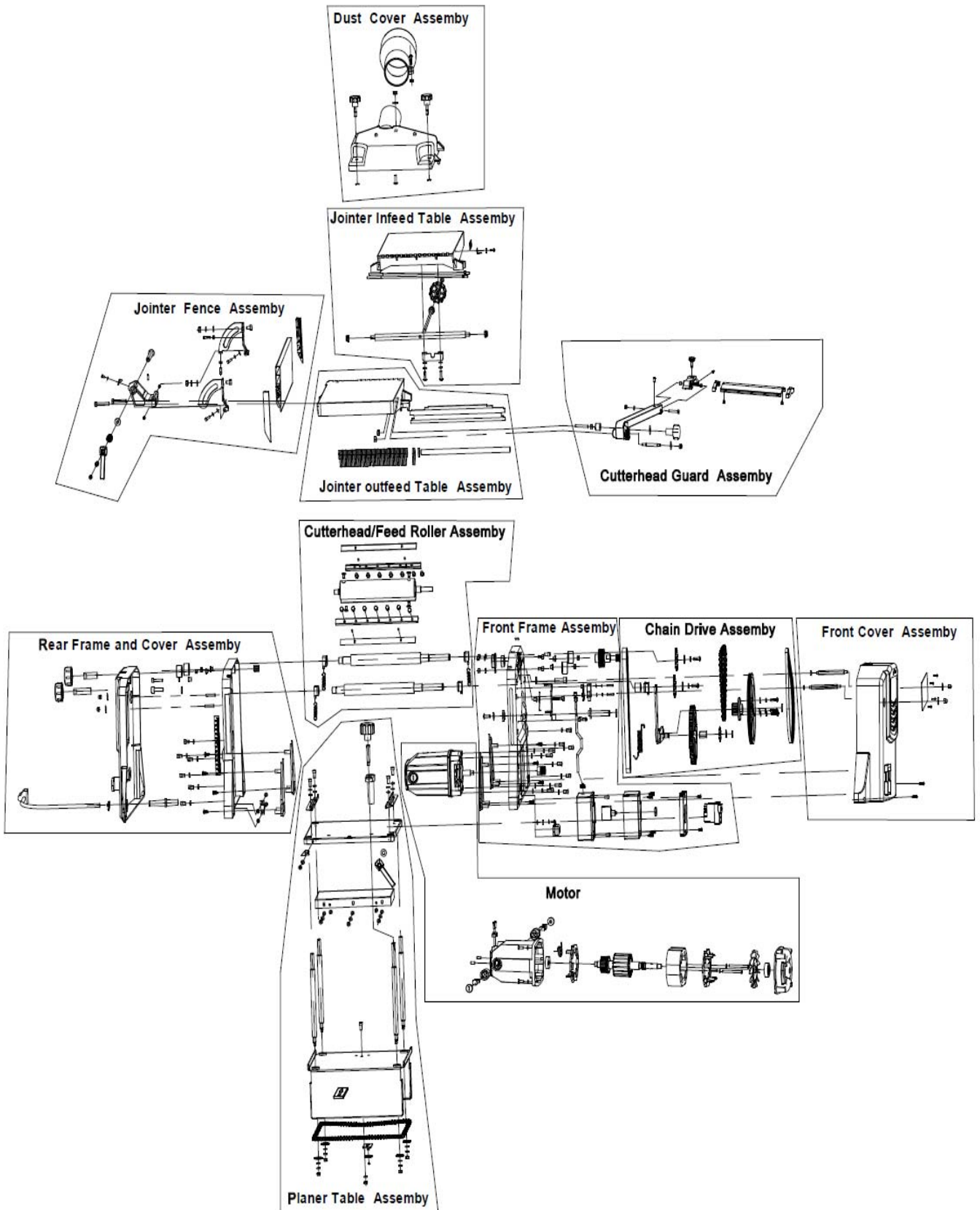

Parts Breakdown for JPT-8B-M Planer Table Assembly

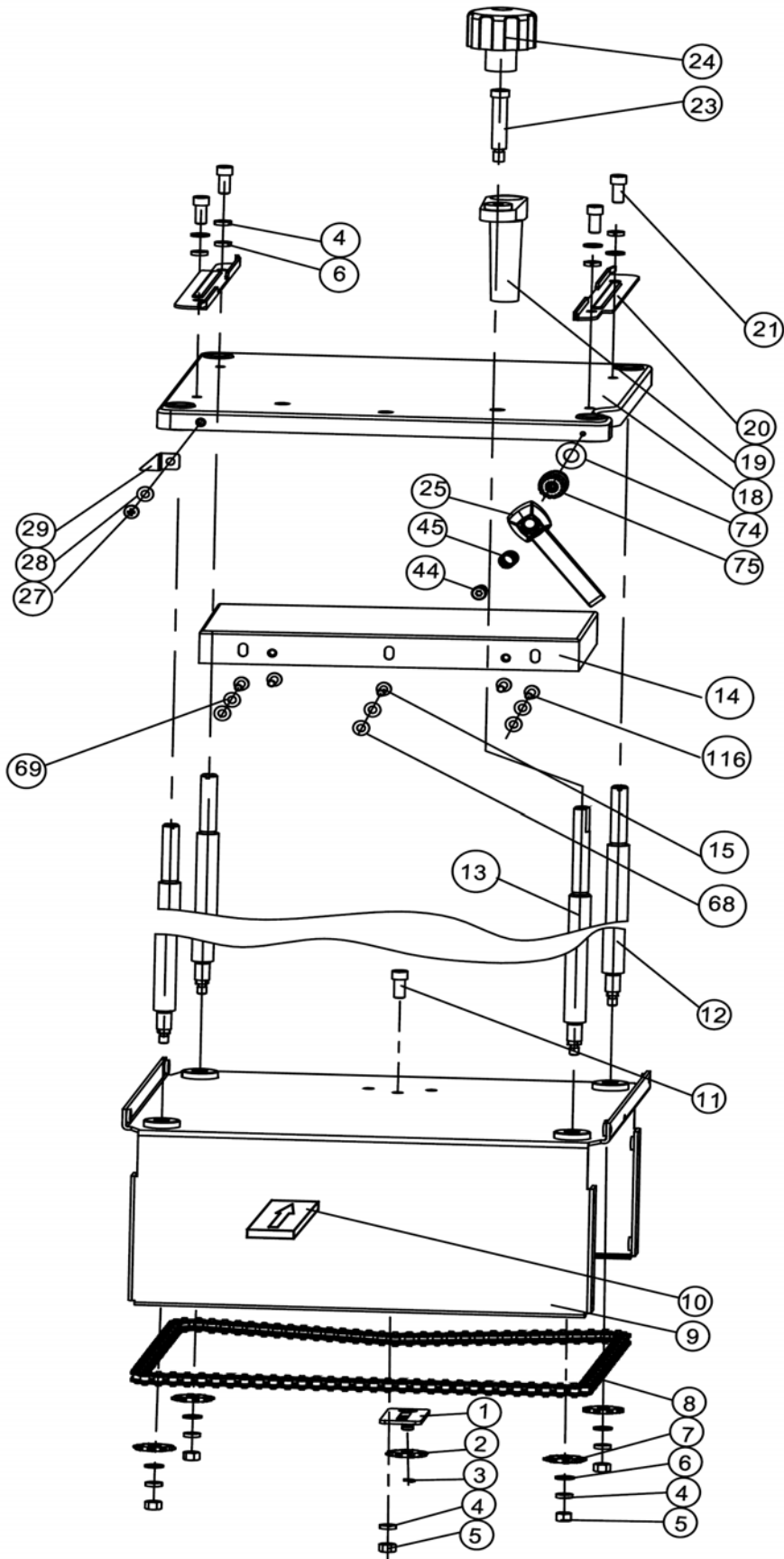

Parts Breakdown for JPT-8B-M Motor Assembly

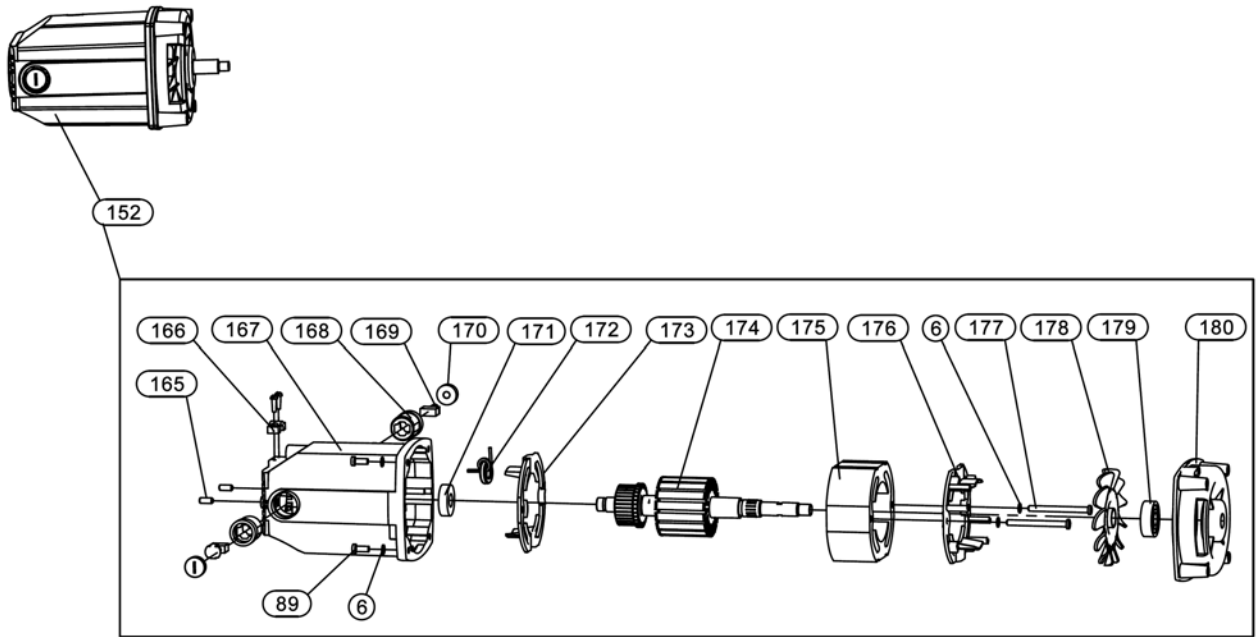

Parts Breakdown for JPT-8B Front Frame Assembly

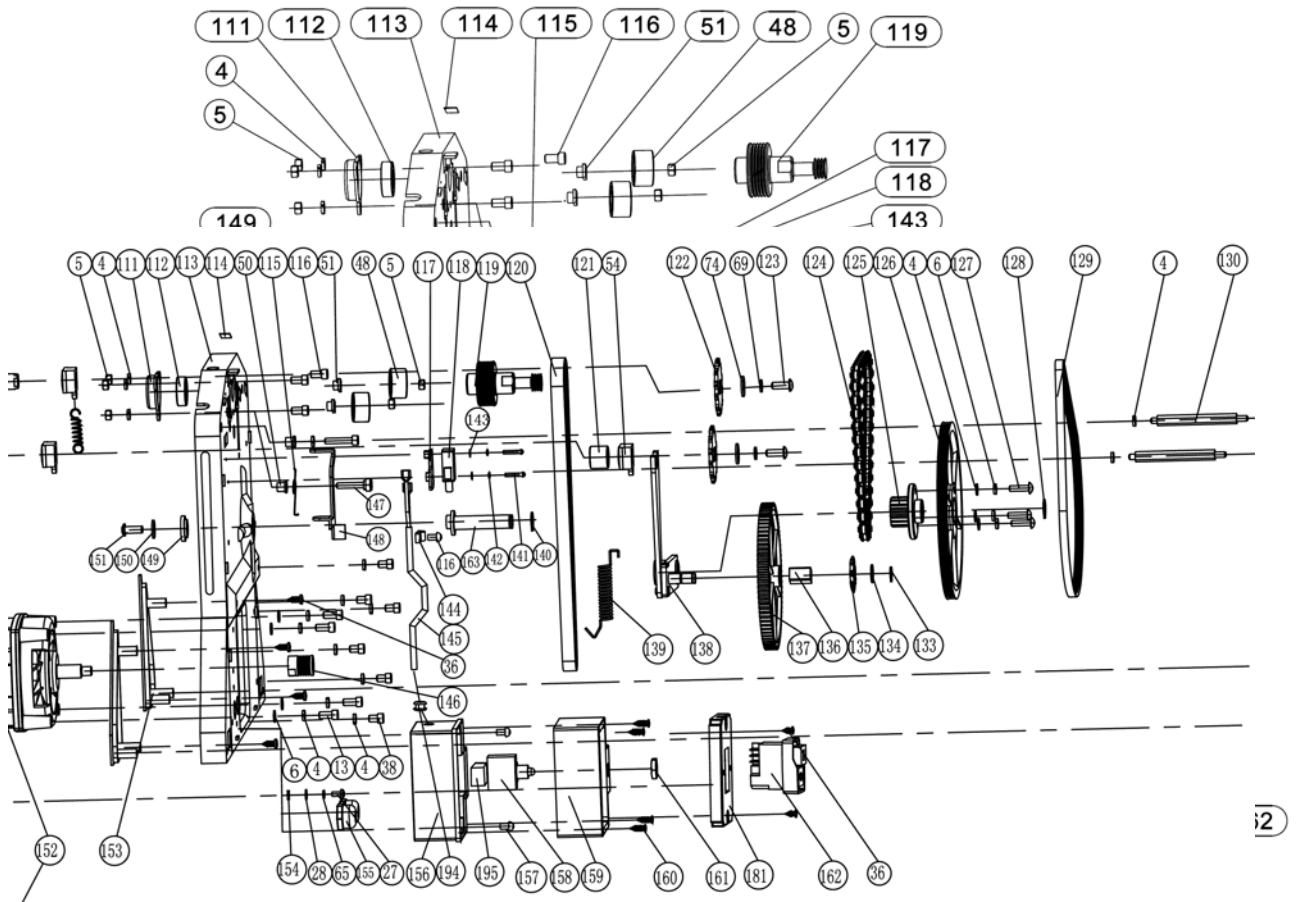

Parts Breakdown for JPT-8B-M Chain Drive Assembly

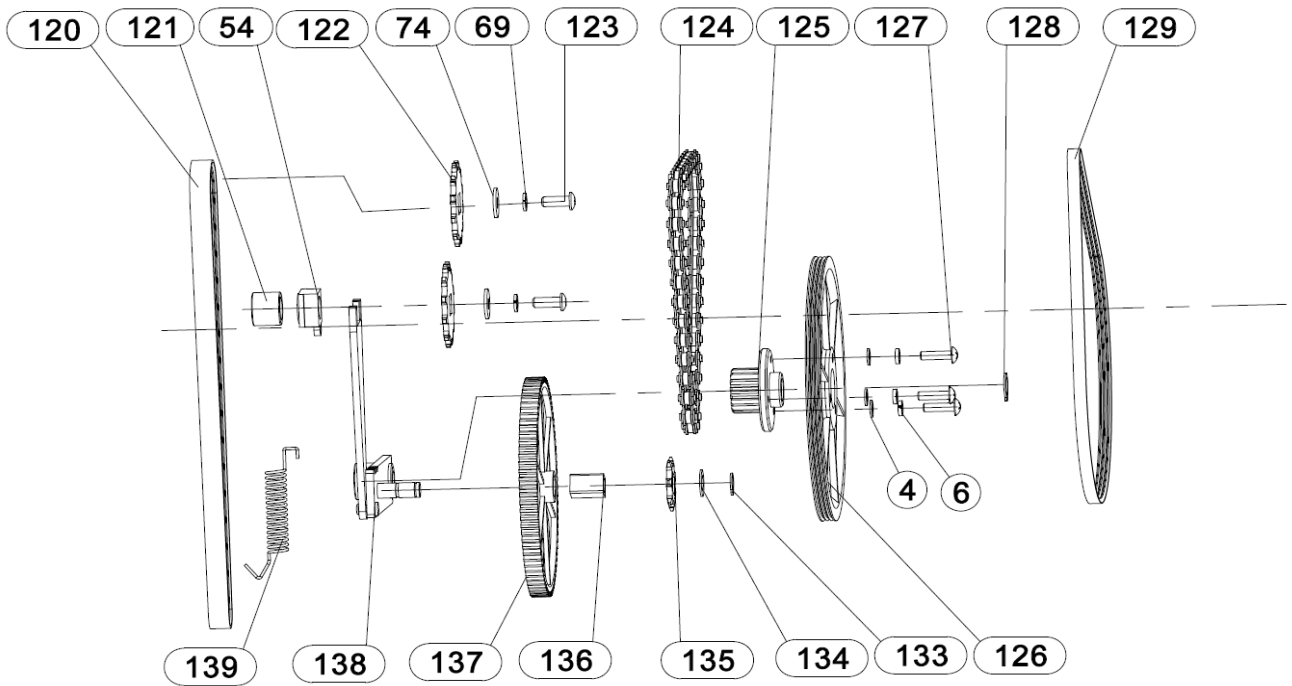

Parts Breakdown for JPT-8B-M Front Cover Assembly

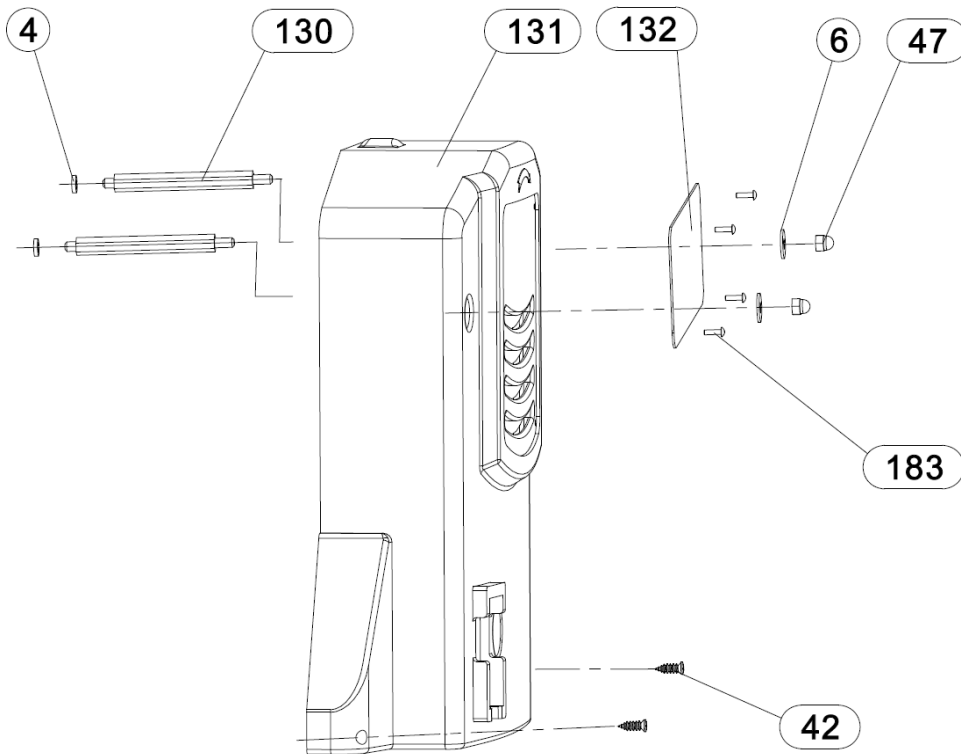

Parts Breakdown for JPT-8B-M Cutterhead Guard Assembly

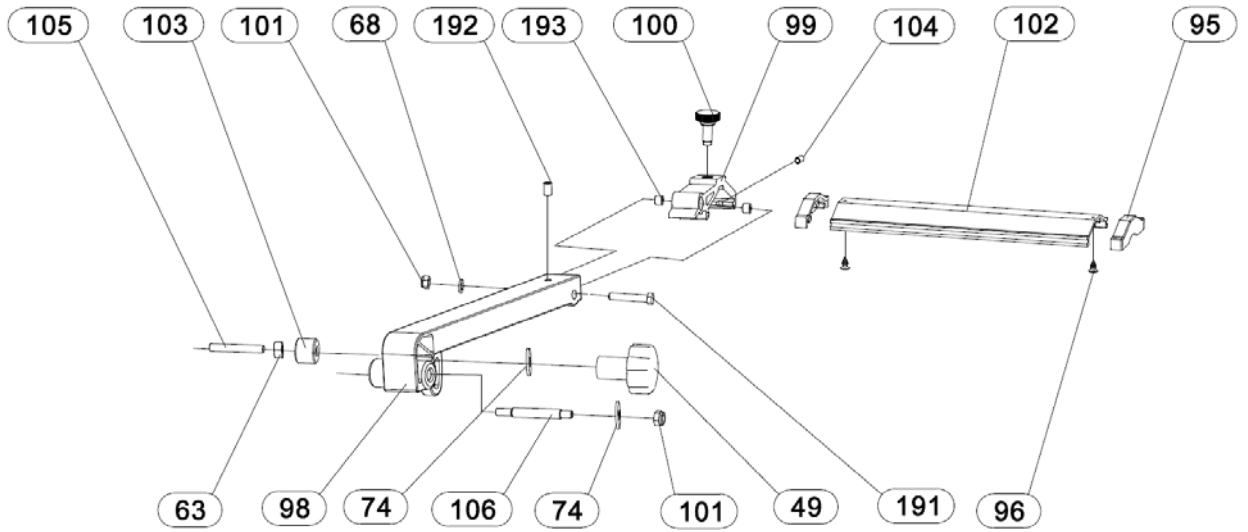

Parts Breakdown for JPT-8B-M Dust Cover Assembly

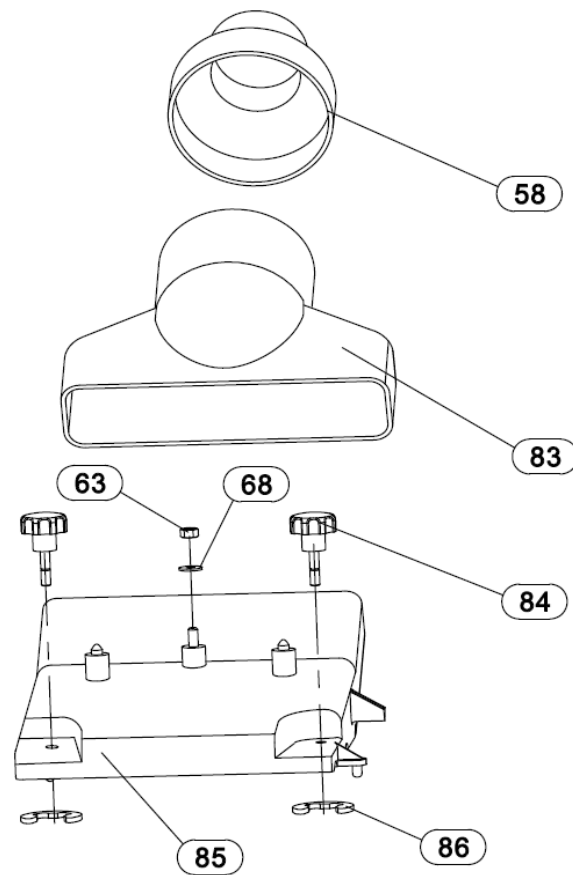

Parts Breakdown for JPT-8B-M Jointer Infeed Table Assembly

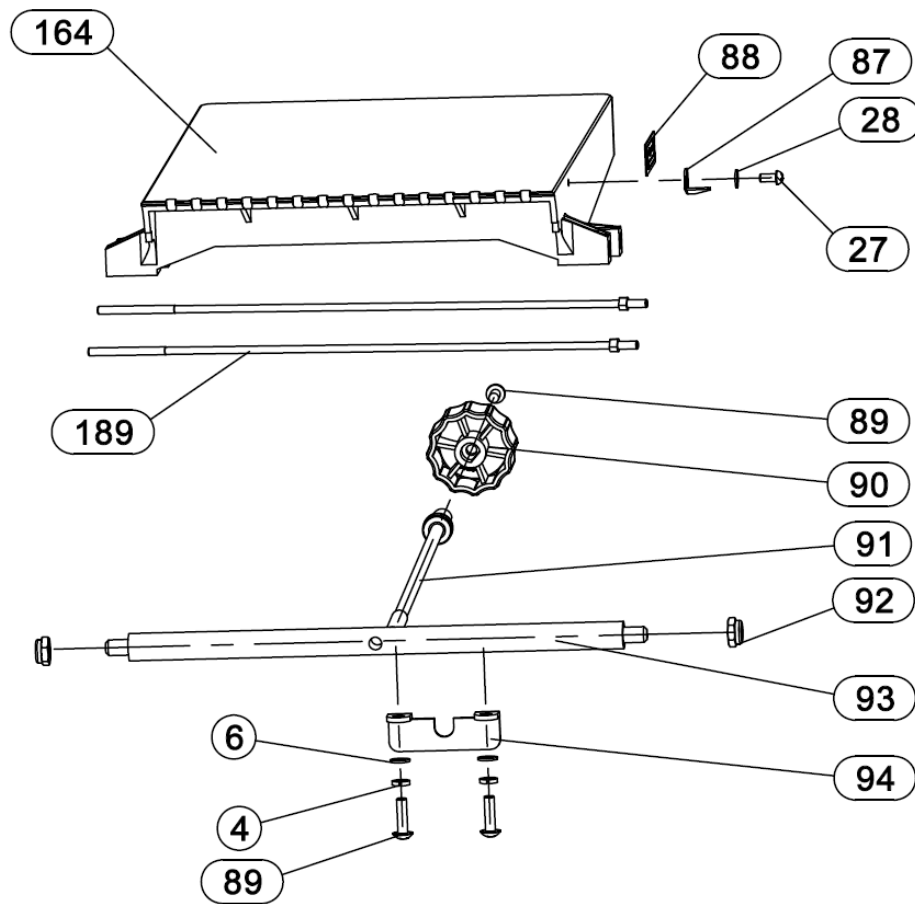

Parts Breakdown for JPT-8B-M Jointer Outfeed Table Assembly (8")

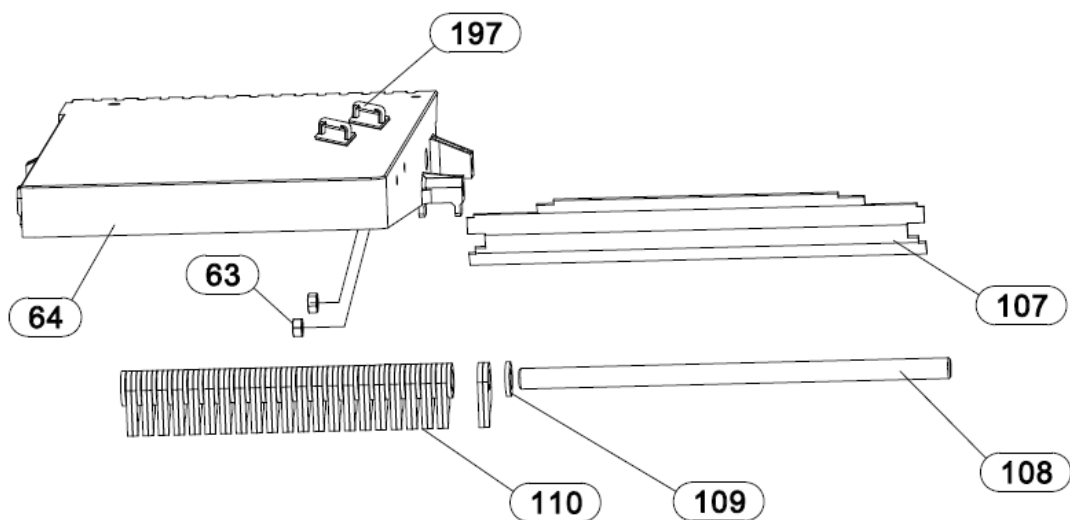

Parts Breakdown for JPT-8B-M Cutter Head/Feed Roller Assembly

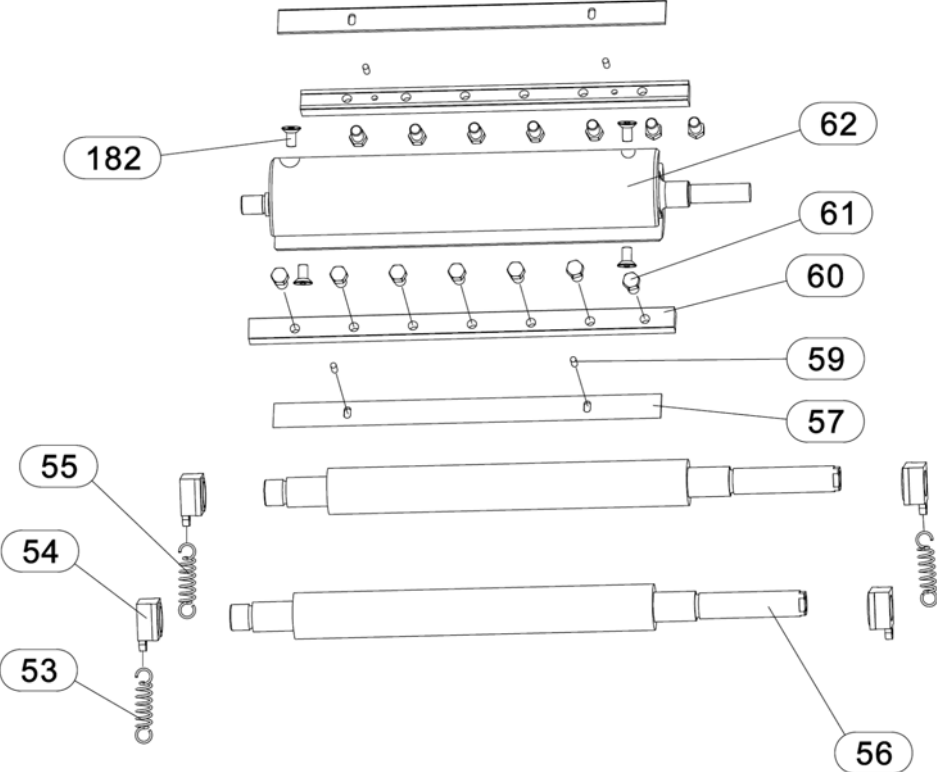

Parts Breakdown for JPT-8B-M Jointer Fence Assembly

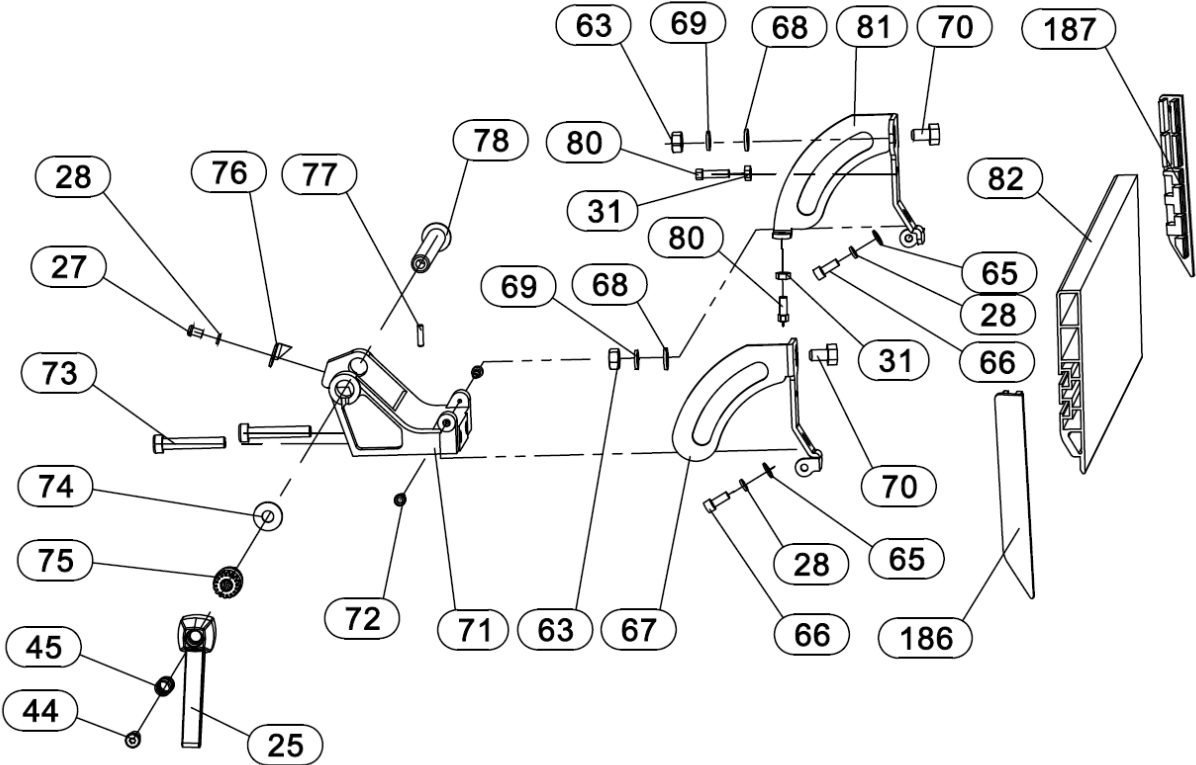

Parts Breakdown for JPT-8B-M Rear Frame and Cover Assembly

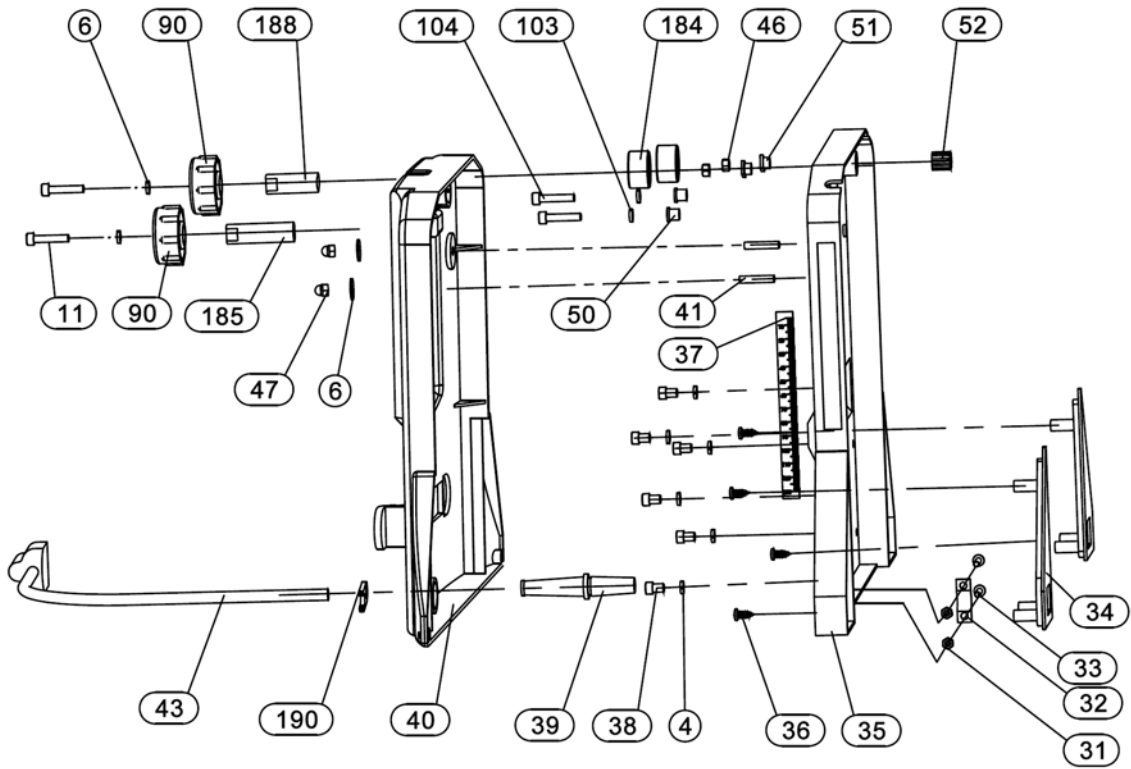

Parts List for JPT-8B-M Planer & Thicknesser

Index No.	Part No.	Description	Size	Qty
1	JJP8BT-1	Chain Support Bracket		1
2	JJP8BT-2	Sprocket		1
3	JJP8BT-3	E-Clip	Ø6	1
4	TS-2361051	Lock Washer	5	38
5	TS-1540031	Hex Nut	5	7
6	TS-1550031	Flat Washer	5	24
7	JJP8BT-7	Corner Sprocket		4
8	JJP8BT-8	Chain		1
9	JJP8BT-9	Base		1
10	JJP8BT-10	Infeed Pointer Label		1
11	TS-1502031	Socket Head Cap Screw	M5x12	3
12	JJP8BT-12	Driven Lead Screw		3
13	JJP8BT-13	Drive Lead Screw		1
14	JJP8BT-14	Extension Table		1
15	TS-1503021	Socket Head Cap Screw *	M6x10	3
18	JJP8BT-18	Main Table		1
	JJP8BT-19A	Elevating Handle Assembly (includes #19,23,24)		1
19	JJP8BT-19	Crank Arm		1
20	JJP8BT-20	Guide Rail		2
21	TS-1503041	Socket Head Cap Screw	M6x16	4
23	JJP8BT-23	Knob Screw		1
24	JJP8BT-24	Knob		1
	JJP8BT-25A	Locking Handle Assembly (includes #25,44,45,75)		1
25	JJP8BT-25	Locking Handle		2
27	TS-1532032	Pan Head Machine Screw	M4x10	3
28	TS-2361041	Lock Washer	M4	3
29	JJP8BT-29	Pointer		1
31	TS-1540021	Hex Nut	M4	2
32	JJP8BT-32	Cord Clamp		1
33	TS-1532052	Pan Head Machine Screw	M4x16	2
34	JJP8BT-34	Cover		2
35	JJP8BT-35	Rear Support		1
36	JJP8BT-36	Self-Tapping Screw	ST4.2x10	10
37	JPT8T-37EU	Scale		1
38	TS-1502011	Socket Head Cap Screw	M5x8	13
39	JJP8BT-39	Power Cord Protector		1
40	JJP8BT-40	Rear Support Cover		1
41	JJP8BT-41	Pin		2
42	JJP8BT-42	Self-Tapping Screw	ST4.2x20	4
43	JPT8B-43EU	Power Cord		1
44	JJP8BT-44	Screw		2
45	JJP8BT-45	Spring		2
46	JJP8BT-46	Lock Nut	M5	2
47	TS-2331051	Cap Nut	M5	4
48	JJP8BT-48	Thread Lock Bushing		4
49	JPT10B-49EU	Cantilever Knob		1
50	JJP8BT-50	Outfeed Table Spacer		4
51	JJP8BT-51	Infeed Table Spacer		4
52	JJP8BT-52	Bearing	K10×13×13	1
53	JJP8BT-53	Spring		2
54	JJP8BT-54	Bushing Block		5
55	JJP8BT-55	Spring		1
56	JJP8BT-56	Roller		2
57	707401	Knife		2
58	JJP8BT-58	Hose Adapter		1
59	JJP8BT-59	Pin	3x8	4
60	JJP8BT-60	Knife Gib		2
61	JJP8BT-61	Screw		12
62	JJP8BT-62	Cutterhead		1
63	TS-1540041	Hex Nut *	M6	9
64	JPT8B-64EU	Outfeed Table		1

Parts List for JPT-8B-M Planer & Thicknesser

Index No.	Part No.	Description	Size	Qty
65	TS-1550021	Flat Washer	4	3
66	TS-1501041	Socket Head Cap Screw	M4x12	2
67	JJP8BT-67	Fence Support		1
68	TS-1550041	Flat Washer *	M6	8
69	TS-2361061	Lock Washer *	M6	9
70	TS-1482021	Hex Cap Screw	M6x12	2
71	JJP8BT-71	Fence Bracket		1
72	JJP8BT-72	Screw		2
73	TS-1503061	Socket Head Cap Screw *	M6x25	2
74	JJP8BT-74	Washer	Ø6	6
75	JJP8BT-75	Locking Nut		2
76	JJP8BT-76	Angle Pointer		1
77	JJP8BT-77	Pin	3x10	1
78	JJP8BT-78	Shaft		1
80	JJP8BT-80	Hex Cap Screw	M4x15	2
81	JJP8BT-81	Angle Marked Fence Support		1
82	JJP8BT-82	Fence		1
83	JJP8BT-83	Dust Chute		1
84	JJP8BT-84	Knob		2
85	JJP8BT-85	Dust Housing		1
86	JJP8BT-3	E-Clip	Ø6	2
87	JJP8BT-87	Pointer		1
88	JJP8BT-88	Infeed Direction Label		1
89	TS-1533042	Pan Head Machine Screw	M5x12	3
90	JJP8BT-90	Knob		1
	JJP8BT-90L	Lock Knob Assembly – Long (includes #90,185)		1
	JJP8BT-90S	Lock Knob Assembly – Short (includes #90,188)		1
91	JJP8BT-91	Adjusting Rod		1
92	TS-1541031	Nylon Insert Lock Nut		2
93	JJP8BT-93	Shaft		1
94	JJP8BT-94	Bracket		1
95	JPT10B-95EU	Cushion Block		2
96	JJP10B-96EU	Self-Tapping Screw	ST4.2x6	2
98	JPT10B-98EU	Cutterblock guard assembly		1
99	JPT10B-99EU	Base for Cutterhead Guard		1
100	JPT10B-100EU	Locking Knob		1
101	JPT10B-101EU	Locking Nut		1
102	JPT8B-102EU	Cutterhead Guard		1
103	JPT10B-103EU	Lock Washer		2
104	TS-1504051	Socket Head Cap Screw	M8x25	2
105	JPT10B-105EU	Shaft		1
106	JPT10B-106EU	Shaft		1
107	JJP8BT-107	Shield		1
108	JJP8BT-108	Shaft		1
109	JJP8BT-109	Washer		28
110	JJP8BT-110	Anti-Kickback Finger		54
111	JJP8BT-111	Bearing Cover		1
112	JJP8BT-112	Bearing		1
113	JJP8BT-113	Front Support		1
114	JJP8BT-114	Cut Depth Scale Label		1
115	JJP8BT-115	Spring		1
116	TS-1502021	Socket Head Cap Screw	M5x10	6
117	JJP8BT-117	Limit Switch Mount		1
118	JJP8BT-118	Limit Switch		1
119	JJP8BT-119	Pulley		1
120	JJP8BT-120	Belt	5PJ604	1
121	JJP8BT-121	Spacer		1
122	JJP8BT-122	Sprocket		2
123	JJP8BT-123	Socket Head Cap Screw	M6x15	2
124	JJP8BT-124	Drive Chain		1

Parts List for JPT-8B-M Planer & Thicknesser

Index No.	Part No.	Description	Size	Qty
125	JJP8BT-125	Gear		1
126	JJP8BT-126	Pulley		1
127	TS-1533062	Pan Head Machine Screw	M5x20	3
128	JJP8BT-128	Key		1
129	JJP8BT-129	Belt		1
130	JJP8BT-130	Shaft		2
131	JJP8BT-131	Front Support Cover		1
132	JJP8BT-132	JET Nameplate		1
133	JJP8BT-133	Key		1
134	JJP8BT-134	Washer		1
135	JJP8BT-135	Sprocket		1
136	JJP8BT-136	Square Spacer		1
137	JJP8BT-137	Gear		1
138	JJP8BT-138	Gear Bracket		1
139	JJP8BT-139	Spring		1
140	JJP8BT-140	Key		1
141	JJP8BT-141	Pan Head Machine Screw	M3x18	2
142	TS-2361031	Lock Washer	M3	2
143	TS-1550011	Flat Washer	M3	2
144	JJP8BT-144	Wire Clamp		1
145	JPT8B-145EU	Wire		1
146	JJP8BT-146	Motor Pulley		1
147	JJP8BT-147	Screw		1
148	JJP8BT-148	Bracket		1
149	JJP8BT-149	Washer		1
150	TS-2361081	Lock Washer	M8	1
151	JJP8BT-151	Socket Head Cap Screw	M8x15	1
152	JPT10B-152EU	Motor		1
153	JJP8BT-153	Cover		2
154	JJP8BT-154	Star Washer	M4	1
155	JJP8BT-155	Strain Relief		2
156	JJP8BT-156	Switch Box		1
157	TS-1533032	Pan Head Machine Screw	M5x10	2
158	JPT8B-158EU	Overload Switch	7A	1
159	JJP8BT-159	Switch Box Cover		1
160	JJP8BT-160	Self-Tapping Screw	ST4.2x15	4
161	JJP8BT-161	Nut		1
162	JPT10B-162EU	Switch	KJD17F	1
163	JJP8BT-163	Shaft		1
164	JPT8B-164EU	Infeed Table		1
165	TS-1521051	Set Screw	M4x12	2
166	JPT10B-166	Cord Clamp		1
167	JPT10B-167	Motor Housing		1
168	JJP8BT-168	Brush Holder		2
169	JJP8BT-169	Brush		2
170	JJP8BT-170	Brush Cap		2
171	JPT10B-171	Bearing	60101	1
172	JPT10B-172	Inductor		1
173	JPT10B-173	Stator Insulation Pan		1
174	JPT10B-174	Armature		1
175	JPT10B-175	Stator		1
176	JPT10B-176	Stator Insulation Pan		1
177	JPT10B-177	Self-Tapping Screw	ST5x56	2
178	JJP8BT-178	Fan		1
179	JPT10B-179	Bearing	60201	1
180	JJP8BT-180	Motor Cover		1

Parts List for JPT-8B-M Planer & Thicknesser

Index No.	Part No.	Description	Size	Qty
181	JPT10B-181EU	Switch Box Faceplate		1
182	JJP8BT-182	Jack Screw		4
183	JJP8BT-183	Rivet	Ø3x10	4
184	JJP8BT-184	Lock Sleeve		2
185	JJP8BT-185	Lock Shaft 1 (Long)		1
186	JJP8BT-186	Fence End Cover 1		1
187	JJP8BT-187	Fence End Cover 2		1
188	JJP8BT-188	Lock Shaft 2 (Short)		1
189	JJP8BT-189	Rod		2
190	JJP8BT-190	Cord Clamp		1
191	JPT10B-191EU	Screw		1
192	JPT10B-192EU	Set Screw	M6x10	2
193	JPT10B-193EU	Sleeve		2
195	JPT10B-195EU	Capacitor	0.33uf	1
196	JPT10B-196EU	Cutterhead Guard Assembly(includes #49,63,74, #95 thru 106 ; 192#)		1
197	JJP8BT-197	Push Block		2
	JJP8BT-KSG	Knife/Blade Setting Gauge (not shown)		1
	JJP10BT-HP	Hardware Package (*)		1
	JPT8BT-201	ID Label, JPT-8B (not shown)		1
	JPT10B-202	Motor Label, JPT-10B (not shown)		1
	JPT10B-203	Warning Label, JPT-10B (not shown)		1
	JPT10B-204	Open-end wrench (not shown)	8-10mm	1
	JPT10B-205	Hex wrench (not shown)	3mm	1
	JPT10B-206	Hex wrench (not shown)	5mm	1
	TS-152707	Hex wrench (not shown)	6mm	1

Note: Some parts may be listed for reference, but are only available as part of a larger assembly.

* Items with asterisk are included in JPT8B-M-HP (Hardware Package).

Parts Breakdown for JPT-8B-M Planer & Thicknesser Stand ¹

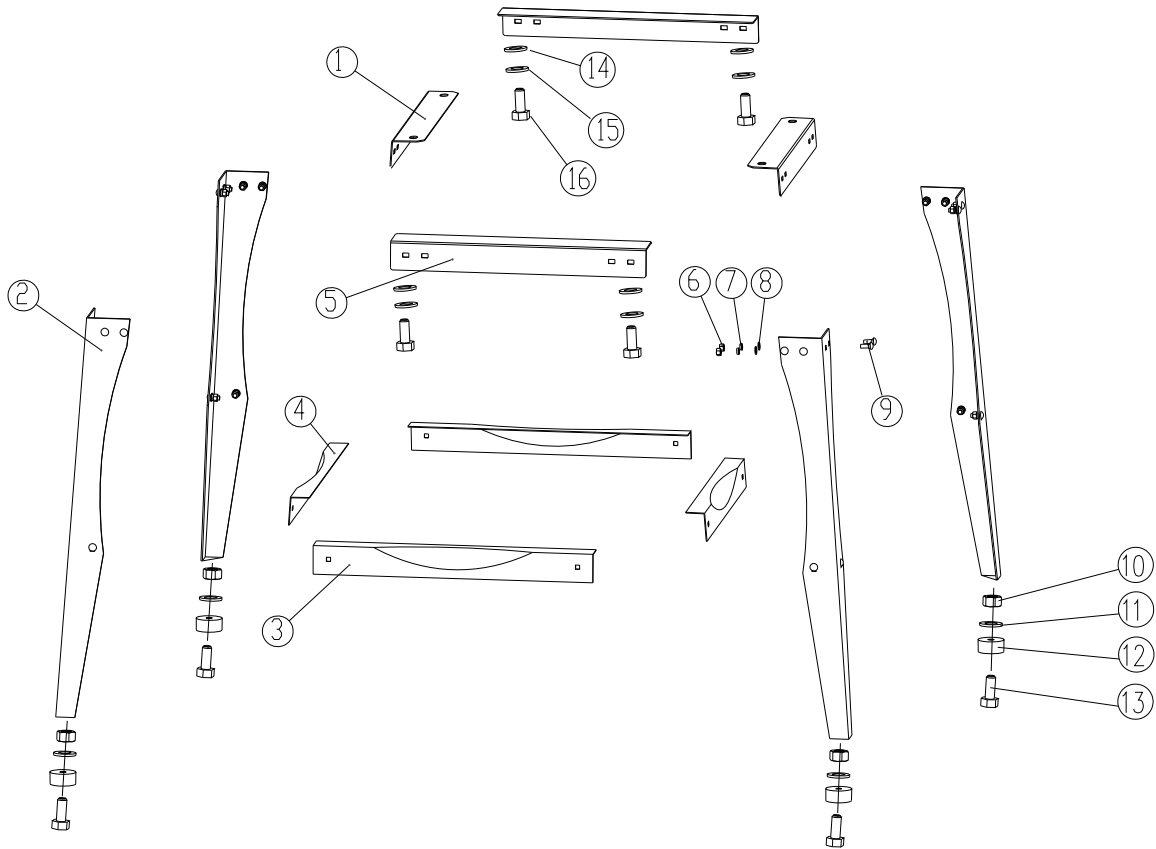

Part list for JPT-8B-M Planer & Thicknesser Stand ¹

Index No.	Part No.	Description	Size	Qty
1	JJP10BT-901	Stand Top Support, Short		2
2	JJP10BT-902	Leg		4
3	JJP10BT-903	Support Plate, Long		2
4	JJP10BT-904	Support Plate, Short		2
5	JJP10BT-905	Stand Top Support, Long		2
6	TS-1540041	Hex Nut *	M6	24
7	TS-2361061	Lock Washer *	M6	24
8	TS-1550041	Flat Washer *	M6	24
9	708315-63	Carriage Bolt *	M6x12	24
10	TS-1540041	Hex Nut	M6	4
11	TS-1550041	Flat Washer	M6	4
12	JJP10BT-912	Rubber Foot *		4
13	TS-1482041	Hex Cap Screw *	M6x20	4
14	TS-1550061	Flat Washer *	M8	4
15	TS-2361081	Lock Washer *	M8	4
16	TS-1504041	Socket Head Cap Screw *	M8x20	4

* Items with asterisk are included in JPT-10B-HP (Hardware Package).

¹ This item is an optional accessory. To order, call our service department and request Stand for JPT-8B-M, stock number # 707402.

Wiring Diagram for JPT-8B-M Planer & Thicknesser

707400M.....1~ 230V, PE, 50Hz

	colour of strands	Litzenfarben	couleur des cordons
BK	black	schwarz	noir
WH	white	weiß	blanc
BU	blue	blau	bleu
YE	yellow	gelb	jaune
RD	red	rot	rouge
BN	brown	braun	brun
GY	grey	grau	gris
GNYE	green-yellow	grün-gelb	vert-jaune
OG	orange	orange	orange
VT	violet	violett	violet

	meaning of symbol	Bedeutung der Zeichen	interprétation
M	motor	Motor	moteur
S	switch	Schalter	interrupteur
OL	overload cut-off	Überlastschuttschalter	déclencheur surcharge
LS	limit switch	Positionsendschalter	micro

