



**JRT-1**

**Router Table**

**230V 50Hz 1PH**

**PARTS LIST  
ERSATZTEILLISTE  
LISTE DE PIÈCES**

For machines with serial no. 2019010001 and higher

**TOOL FRANCE SARL**

9 Rue des Pyrénées , 91090 LISSES, France

[www.jettools.com](http://www.jettools.com)

P-10000760M 2019-02



# Parts breakdown for JRT-1 Router Table

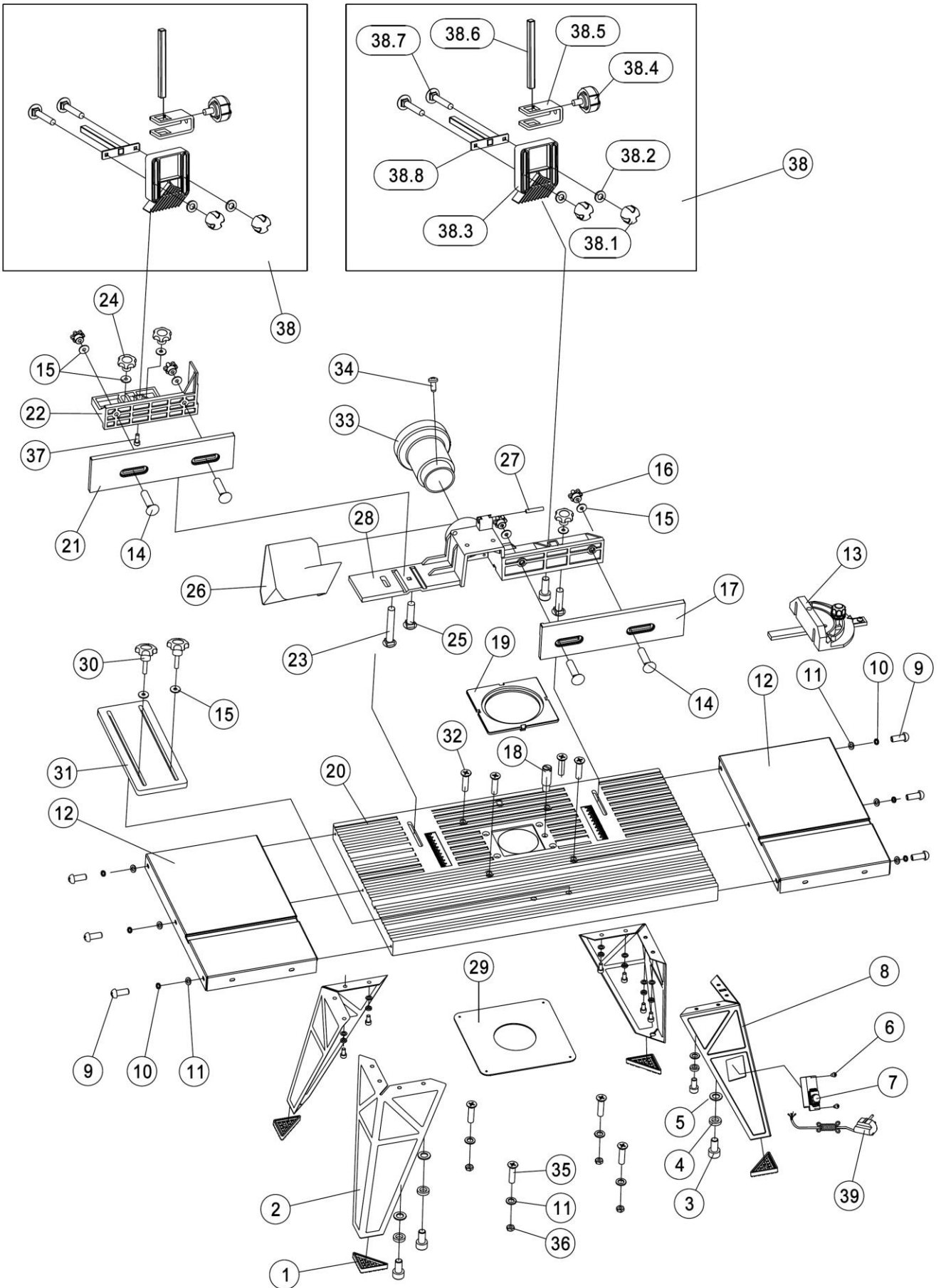

## Parts List for JRT-1 Router Table

Index	Part No.	Description	Size	Qty.
1	JRT1-001	Rubber feet		4
2	JRT1-002	Leg stand A		3
3	JRT1-003	Screw	M6x12	16
4	JRT1-004	Spring washer	6	16
5	JRT1-005	Flat washer	6	16
6	JRT1-006	Tapping screw	ST4.2x9.5	2
7	JRT1-007	Power outlet		1
8	JRT1-008	Leg stand B		1
9	JRT1-009	Screw	M5x12	6
10	JRT1-010	Spring washer	5	6
11	JRT1-011	Flat washer	5	10
12	JRT1-012	Extension table		2
13	JRT1-013	Miter gauge		1
14	JRT1-014	Bolt	M6x15	4
15	JRT1-015	Flat washer	6	9
16	JRT1-016	Knob		4
17	JRT1-017	Right fence		1
18	JRT1-018	Pin		1
19	JRT1-019	Table insert		1set
20	JRT1-020	Work table		1
21	JRT1-021	Left fence		1
22	JRT1-022	Guide fence B		1
23	JRT1-023	Bolt	M6x35	1
24	JRT1-024	Knob		3
25	JRT1-025	Bolt	M6x20	2
26	JRT1-026	Protection guard		1
27	JRT1-027	Pin		1
28	JRT1-028	Guide fence A		1
29	JRT1-029	Fix plate		1
30	JRT1-030	Knob		2
31	JRT1-031	Guide plate		1
32	JRT1-032	Screw	M5x16	4
33	JRT1-033	Adaptor		1
34	JRT1-034	Tapping screw	M4X10	1
35	JRT1-035	Screw	M5X14	4
36	JRT1-036	Nut	M5	4
37	JRT1-037	Socket Head Cap Screw	M6x16	2
38	JRT1-038	Feather Board Assembly (#38.1 thru 38.8)		2
38.1	JRT1-038.1	Knob	M6	4
38.2	JRT1-038.2	Flat Washer	6mm	4
38.3	JRT1-038.3	Feather Board		2
38.4	JRT1-038.4	Knob		2
38.5	JRT1-038.5	Fixed Mount		2
38.6	JRT1-038.6	Bracket A		2
38.7	JRT1-038.7	Square Screw		4
38.8	JRT1-038.8	Bracket B		2
39	JRT1-039	Power Cord		1

## Wiring Diagram for JRT-1 Router Table 10000760M..... ~ 230V, 50/60Hz

	colour of strands	Litzenfarben	couleur des cordons
BK	black	schwarz	noir
WH	white	weiß	blanc
BU	blue	blau	bleu
YE	yellow	gelb	jaune
RD	red	rot	rouge
BN	brown	braun	brun
GY	grey	grau	gris
GNYE	green-yellow	grün-gelb	vert-jaune
OG	orange	orange	orange
VT	violet	violett	violet

	meaning of symbol	Bedeutung der Zeichen	interprétation
M	motor	Motor	moteur
S	switch	Schalter	interrupteur
C	condenser	Kondensator	condensateur
E	electronic unit	Elektronik Einheit	unité électronique
F	fuse	Sicherung	fusible
RS	reversing switch	Drehrichtungsschalter	commu. droite/gauche
S	centrifugal switch	Fliehkraftschalter	déclencheur centrifuge
OL	overload cut-off	Überlastschuttschalter	déclencheur surcharge
LS	limit switch	Positionsendschalter	micro

