

GB - ENGLISH

Operating Instructions

Dear Customer,

Many thanks for the confidence you have shown in us with the purchase of your new PROMAC-machine. This manual has been prepared for the owner and operators of a **JD-3285-M or JD-3285-T drill press** to promote safety during installation, operation and maintenance procedures. Please read and understand the information contained in these operating instructions and the accompanying documents. To obtain maximum life and efficiency from your machine, and to use the machine safely, read this manual thoroughly and follow instructions carefully.

...Table of Contents

1. Declaration of conformity

2. Warranty

3. Safety

Authorized use
General safety notes
Remaining hazards

4. Machine specifications

Technical data
Noise emission
Contents of delivery

5. Transport and start up

Transport and installation
Assembly
Mains connection
Starting operation

6. Machine operation

7. Setup and adjustments

Removing the chuck and arbor
Adjusting the depth stop
Changing spindle speeds
Table tilt adjustment
Return spring adjustment
Cross Laser Adjustment
LED Work Light Adjustment

8. Maintenance and inspection

9. Trouble shooting

10. Environmental protection

11. Available accessories

1. Declaration of conformity

On our own responsibility we hereby declare that this product complies with the regulations* listed on page 2. Designed in consideration with the standards**.

2. Warranty

TOOL FRANCE SARL guarantees that the supplied product(s) is/are free from material defects and manufacturing faults.

This warranty does not cover any defects which are caused, either directly or indirectly, by incorrect use, carelessness, damage due to accidents, repairs or inadequate maintenance or cleaning as well as normal wear and tear.

Further details on warranty (e.g. warranty period) can be found in the General Terms and Conditions (GTC) that

are an integral part of the contract.

These GTC may be viewed on the website of your dealer or sent to you upon request.

TOOL FRANCE SARL reserves the right to make changes to the product and accessories at any time.

3. Safety

3.1 Authorized use

This drill press is designed for drilling wood and machinable metal and plastic materials only. Machining of other materials is not permitted and may be carried out in specific cases only after consulting with the manufacturer.

Never cut magnesium- high danger of fire!

The workpiece must allow to safely be loaded and clamped for machining.

The proper use also includes compliance with the operating and maintenance instructions given in this manual.

The machine must be operated only by persons familiar with its operation and maintenance and who are familiar with its hazards.

The required minimum age must be observed.

The machine must only be used in a technically perfect condition.

When working on the machine, all safety mechanisms and covers must be mounted.

In addition to the safety requirements contained in these operating instructions and your country's applicable regulations, you should observe the generally recognized technical rules concerning the operation of wood- and metal-working machines.

Any other use exceeds authorization. In the event of unauthorized use of the machine, the manufacturer renounces all liability and the responsibility is transferred exclusively to the operator.

3.2 General safety notes

Drill press can be dangerous if not used properly. Therefore the appropriate general technical rules as well as the following notes must be observed.



Read and understand the entire instruction manual before attempting assembly or operation.



Keep this operating instruction close by the machine, protected from dirt and humidity, and pass it over to the new owner if you part with the tool.

No changes to the machine may be made.

Daily inspect the function and existence of the safety appliances before you start the machine. Do not attempt operation in this case, protect the machine by unplugging the power cord.

Before operating the machine, remove tie, rings, watches, other jewellery, and roll up sleeves above the elbows. Remove all loose clothing and confine long hair.

Wear safety shoes; never wear leisure shoes or sandals.

Always wear the approved working outfit:

- safety goggles
- ear protection
- dust protection



Do not wear gloves while operating this machine.



Install the machine so that there is sufficient space for safe operation and workpiece handling.

Keep work area well lighted.

The machine is designed to operate in closed rooms and must be bolted stable on firm and levelled table surface or on the supplied cabinet stand.

Make sure that the power cord does not impede work and cause people to trip.

Keep the floor around the machine clean and free of scrap material, oil and grease.

Stay alert!
Give your work undivided attention.

Use common sense. Do not operate the machine when you are tired.

Keep an ergonomic body position. Maintain a balanced stance at all times.

Do not operate the machine under the influence of drugs, alcohol or any medication. Be aware that medication can change your behaviour.



Never reach into the machine while it is operating or running down.



Keep children and visitors a safe distance from the work area.

Never leave a running machine unattended. Before you leave the workplace switch off the machine.

Do not operate the electric tool near inflammable liquids or gases. Observe the fire fighting and fire alert options, for example the fire extinguisher operation and place.

Do not use the machine in a damp environment and do not expose it to rain.

Before machining, remove any nails and other foreign bodies from the workpiece.

Work only with well sharpened tools.

Machine only stock which rests securely on the table.

Always close the chuck cover before you start the machine.

Specifications regarding the maximum or minimum size of the workpiece must be observed.

Do not remove chips and workpiece parts until the machine is at a standstill.

Do not stand on the machine.

Connection and repair work on the electrical installation may be carried out by a qualified electrician only.



Have a damaged or worn power cord replaced immediately.

Make all machine adjustments or maintenance with the machine unplugged from the power source.



Never place your fingers in a position where they could contact the drill or other cutting tool if the work piece should unexpectedly shift or your hand should slip.

Secure workpiece against rotation. Use fixtures, clamps or a vice to hold the workpiece. Never hold the workpiece with your hands alone.

Whenever possible, position the work piece to contact the left side of the column. If it is too short or the table is tilted, clamp solidly to the table. Use the table slots or clamping ledge around the outside of the table.

When using a drill press vice, always fasten it to the table.

Never do any works "freehand" (hand-holding the work piece rather than supporting it on the table), except when polishing.

Securely lock the head to the column and the table bracket to the column before operating the press.

Never move the head or the table while the machine is running.

If a work piece overhangs the table such that it will fall or tip if not held, clamp it to the table or provide auxiliary support.

Do not use wire wheels, router bits, shaper cutters, circle cutters, or rotary planers on this drill press.

To avoid injury from parts thrown by the spring, follow instructions exactly as given when adjusting the spring tension of the quill.

To avoid injury from parts thrown by the spring, follow instructions exactly as given in chapter 7.5.

3.3 Remaining hazards

When using the machine according to regulations some remaining hazards may still exist.

The rotating drill bit can cause injury.

Thrown workpieces and workpiece parts can lead to injury.

Dust, chips and noise can be health hazards. Be sure to wear personal protection gear such as safety goggles and dust mask. Use a suitable dust collection system.

The use of incorrect mains supply or a damaged power cord can lead to injuries caused by electricity.

4. Machine specifications

4.1 Technical data

Drilling capacity (Iron/Steel)	32/32mm
Spindle to column	215mm
Spindle travel	85mm
Spindle taper	MT-3/B16
Chuck size	16mm
Column diameter	80mm
Table size	290 x 290 mm
Overall height	1050 mm
Number of speeds	16
Range of speeds	180 - 3000 rpm
Net weight	61 kg

JD-3285-M:

Mains	230V ~1/N/PE 50Hz
Output power	0.75 kW (1 HP) S1
Reference current	4.6 A
Extension cord (H07RN-F):	3x1.5mm ²
Installation fuse protection	10A

JD-3285-T:

Mains	400V ~3L/N/PE 50Hz
Output power	0.75 kW (1 HP) S1
Reference current	2.4 A
Extension cord (H07RN-F):	5x1.5mm ²
Installation fuse protection	10A

4.2 Noise emission

Acoustic pressure level

(according to EN ISO 11202):

Idling LpA 71,8 dB(A)

In operation LpA 84,0 dB(A)

The specified values are emission levels and are not necessarily to be seen as safe operating levels.

As workplace conditions vary, this information is intended to allow the user to make a better estimation of the hazards and risks involved only.

4.3 Content of delivery

Head assembly
Table
Column and bracket assembly
Machine base
16mm keyless chuck
MT-3 arbor
3 downfeed handles
Table bracket lock handle
Table bracket rising handle
Drill chuck guard
Drift key
Operating tools
Assembly kit
Operating manual
Spare parts list.

5. Transport and start up

5.1 Transport and installation

The machine is designed to operate in closed rooms and must be placed stable on firm and levelled ground. The machine can be bolted down if required.

For packing reasons the machine is not completely assembled.

5.2 Assembly

If you notice transport damage while unpacking, notify your supplier immediately. Do not operate the machine!

Dispose of the packing in an environmentally friendly manner.

Clean all rust protected surfaces with a mild solvent.

Attach the column assembly (A, Fig. 1) to the base (B, Fig. 1) with four M10 hex cap bolts (C, Fig. 1). Tighten firmly.

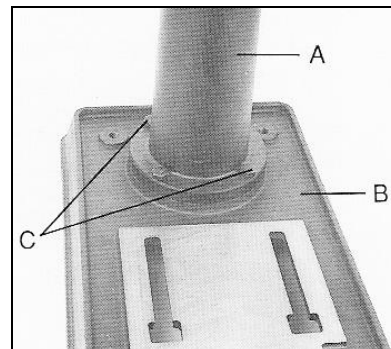

Fig 1

Thread the table bracket lock handle (A, Fig 2) into the table bracket (B, Fig 2).

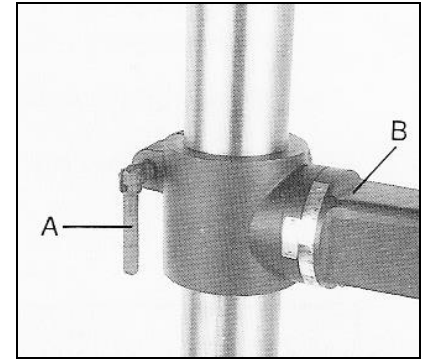

Fig 2

Slide the table bracket rising handle (B, Fig 3) onto the table bracket shaft.

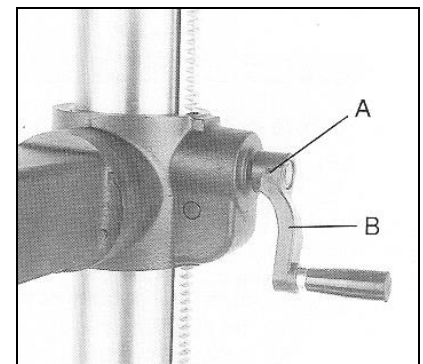

Fig 3

Turn the handle until the set screw is opposite the flat section on the shaft and tighten the set screw (A, Fig 3).

Insert the table into the table bracket.

Tighten the table lock handle.

With the aid of a second person, carefully lift the head onto the column top.

Caution: The head assembly is heavy! Use care when lifting onto the column!

Rotate the head assembly until the sides of the belt cover are parallel with the sides of the base.

Tighten two set screws (A, Fig. 4).

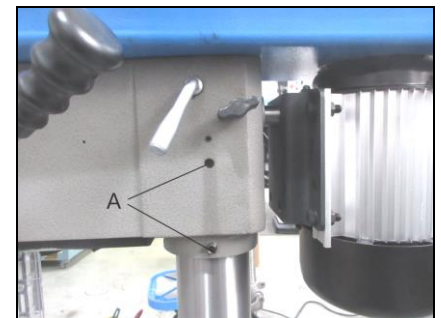

Fig 4

Install three down feed handles (A, Fig. 5) into the down feed hub (B).

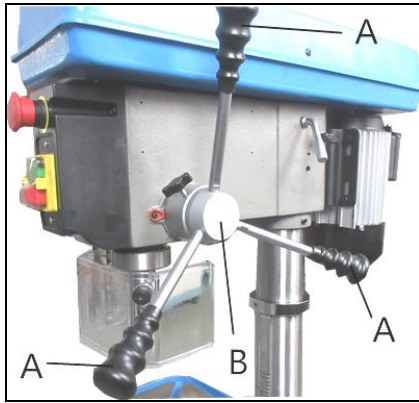

Fig 5

The Drill Chuck Guard Adjustment (Fig. 6.1).

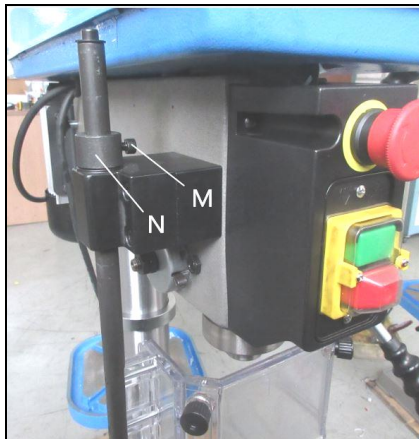

Fig 6.1

This clear plastic shield should be used whenever conducting a drilling or tapping operation. Clean the safety shield periodically to provide a clear view of the work piece. Adjustments can be done as follows.

1. Adjust the internal cover shield to have better range protection.
2. If both internal and external shields cannot provide enough protection, loosen locking bolt (M) to shift setting ring (N) in proper position.

Note: Make sure the bolt (M) aligning to the groove (aimed by the arrow), otherwise the interlock switch would not be triggered when the shields being opened (Fig. 6.2).

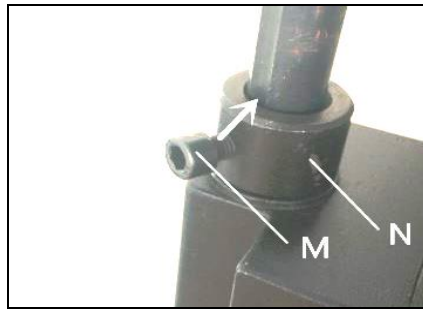

Fig. 6.2

Raise the table to approximately 200mm below the spindle assembly.

Lock the table.

Place a piece of scrap wood on the table.

Thoroughly clean the spindle opening, the arbor, and the chuck.

Important:

These three pieces must be free of any rust protection or lubricant. If they are not clean, the arbor and chuck will fail to seat in the spindle and will fall out.

Place the arbor into the chuck.

Twist the chuck to retract the chuck jaws if they are exposed.

Place the arbor and chuck assembly into the spindle.

Turn the arbor and chuck assembly until the tang on the arbor engages the slot at the end of the spindle.

Lower the down feed handle so that the chuck meets the scrap wood. Pressure on the down feed handle once the chuck meets the scrap wood seats the arbor and chuck into the spindle (see Fig 7).



Fig 7

5.3 Mains connection

Mains connection and any extension cords used must comply with applicable regulations.

The mains voltage must comply with the information on the machine licence plate.

The mains connection must have a 10 A surge-proof fuse.

Only use power cords marked H07RN-F

Connections and repairs to the electrical equipment may only be carried out by qualified electricians.

5.4 Starting operation

You can start the machine with the green on button. The red button on the main switch stops the machine (Fig. 8).



Fig 8

6. Machine operation

Always adjust the table and the depth stop to prevent drilling into the table. Use a back-up piece of scrap wood to cover the table. This protects both the table and the drill bit.

Secure workpiece to the table with clamps or a vice to prevent rotating with the drill bit.

Feed the bit into the material with only enough force to allow the drill bit to work. Feeding too slowly may cause burning of the workpiece. Feeding too quickly may cause the motor to stop and/or the drill bit to break.

Recommended speeds for a 10mm HSS drill:

Wood:	2000 RPM
Plastic:	1500 RPM
Aluminum:	1500 RPM
Brass:	1500 RPM
Cast iron:	1000 RPM
Mild steel:	800 RPM
High carbon steel:	600 RPM
Stainless steel:	300 RPM

Generally speaking, the smaller in relation the drill bit, the greater the RPM required.

Wood requires higher speeds than metal.

Metal is usually drilled at slower speeds; cutting oil is applied if necessary.

Warning:

Always keep your hands well clear of the rotating bit.

Do not remove chips and workpiece parts until the machine is at a standstill.

Always close the chuck guard and pulley cover before you start the machine.

When using a drill press vice, always fasten it to the table.

Never do any works “freehand” (hand-holding the work piece rather than supporting it on the table), except when polishing.

Support long workpieces with helping roller stands.

Do not use wire wheels, router bits, shaper cutters, circle cutters, or rotary planers on this drill press.

Never cut magnesium-high danger of fire!

7. Setup and adjustments

General note:

Setup and adjustment work may only be carried out after the machine is protected against accidental starting by pulling the mains plug.

7.1 Removing the Chuck and Arbor

Unplug the machine from the power source.

Lower the quill using the down feed handle.

Rotate the spindle to align the key in the spindle with the key hole in the quill.

Insert the drift key (A, Fig 9) into the aligned slots and tap lightly. Have another person (or a protected table) catch the chuck and arbor assembly as it falls away from the spindle.

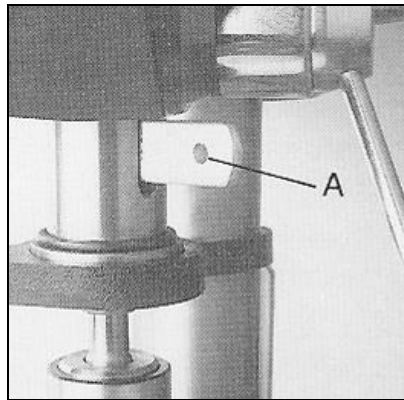

Fig 9

7.2 Adjusting the Depth Stop

To drill multiple holes at the same preset depth, use the depth stop:

With the drill bit in the chuck, lower the down feed handle to advance the chuck to the desired point.

Turn the depth scale collar (C, Fig. 10) counter-clockwise until it stops moving.

Tighten the depth scale lock (D).

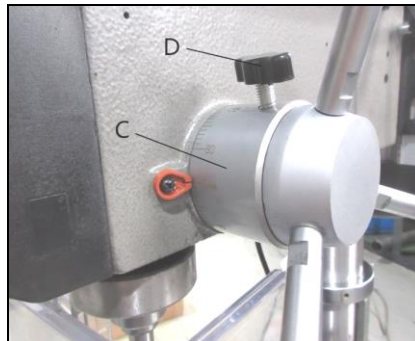

Fig 10

The drill bit will now advance only to this point.

7.3 Changing Spindle Speeds

Loosen the locking screw on the pulley cover, then open the cover.

A spindle speed and belt arrangement chart is found on the inside of the belt cover (Fig 11). Refer to this chart whenever changing speeds.

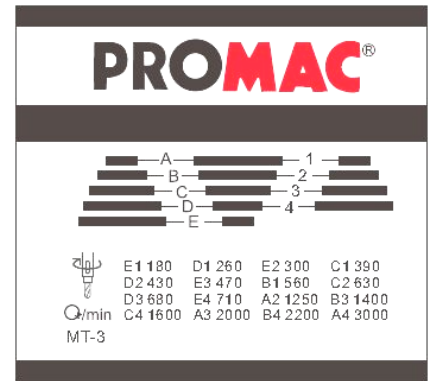

Fig 11

To change spindle speeds:

Unplug the machine from the power source.

Loosen two side bar bolts found on each side of the head assembly. (A, Fig 12).

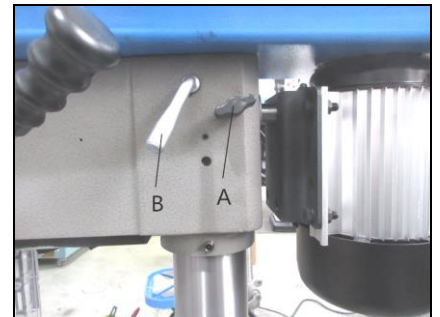

Fig 12

Rotate the tension adjuster (B) to bring the motor base as close to the head as possible.

Change the belts location according the speed chart and the speed you desire.

Rotate the tension adjuster (B) to tension the belts.

Tighten two slide bar bolts (A, Fig. 12). Belts are properly tensioned when finger and thumb pressure midway between the two pulleys causes approximately 10 mm deflection.

Close and lock the pulley cover.

7.4 Table Tilt Adjustment

Disconnect the machine from the power source (unplug).



Fig 13

Loosen the hex cap bolt (C) to tilt the table.

Caution:

Only loosen the hex cap bolt slightly, otherwise the table assembly will separate from the column and fall.

Tighten the hex cap bolt.

7.5 Return Spring Adjustment

Disconnect the machine from the power source (unplug).

The return spring is adjusted at the factory and should not need further adjustment. If adjustment is necessary:

Unplug the machine from the power source.

Loosen two lock nuts (A, Fig 14) approximately 6mm.

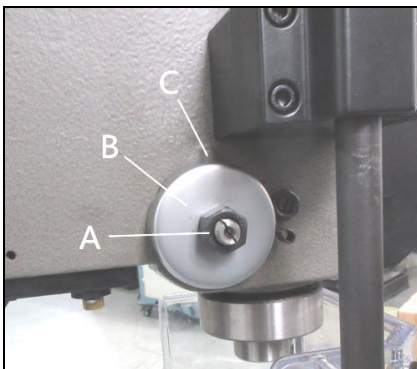

Fig 14

Firmly hold the coil spring cover (B).

Pull out the cover and rotate until the pin (C) on the return spring plate engages the next notch in the coil spring cover. Turn the cover clockwise to decrease tension and counter-clockwise to increase tension.

Tighten two lock nuts (A). Do not over-tighten. Nuts should not contact the housing when tight.

7.6 Cross Laser Adjustment

The lasers are designed for use with twist drill bits.

There will be shadowing with wider tools, such as Forstner bits, therefore use will be limited.

The two laser beams need to meet at the drill centre (Fig 15).

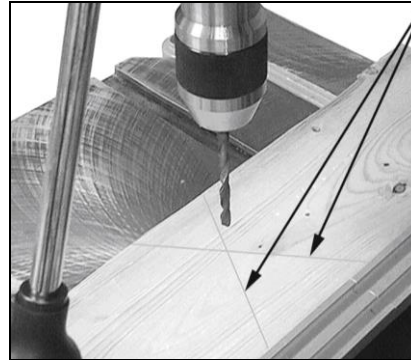

Fig 15

The Laser Assembly has been installed and pre-set at the factory.

To adjust, install a small drill bit and rotate lasers (A, Fig 16) gently with a set of pliers.

Loosen Screw (C) for adjustment.

ATTENTION:

Class 2 Laser

Do not stare into beam of laser

Do not view directly with optical instruments

Do not point the laser beam at people or animals.

Do not use the laser beam on highly reflective materials. Reflected laser light is dangerous.

A defective laser beamer may be replaced only, not repaired.

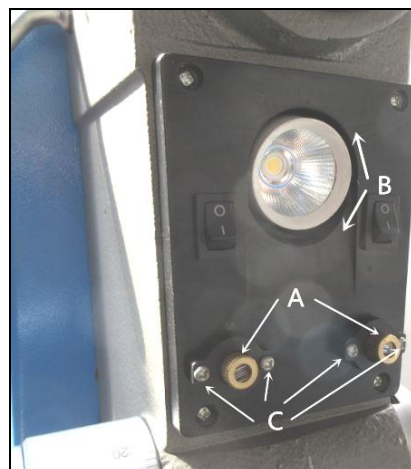

Fig 16

7.7 LED Work Light Adjustment

The integrated LED work light is adjustable.

Push on the rim of the light to adjust (B, Fig 16).

8. Maintenance and inspection

General notes:

Maintenance, cleaning and repair work may only be carried out after the machine is protected against accidental starting by pulling the mains plug.

Lubrication:

Periodically lubricate the gear and the rack, the table elevation mechanism, the drive splines (grooves) in the spindle, and the teeth of the quill gently with grease.

Clean the machine regularly.

Defective safety devices must be replaced immediately.

Repair and maintenance work on the electrical system may only be carried out by a qualified electrician.

9. Trouble shooting

Motor doesn't start

*No electricity-check mains and fuse.

*Defective switch, motor or cord-consult an electrician.

Chuck will not stay on spindle

*Oil or grease on contact surfaces-clean the tapered surfaces of chuck and spindle.

Machine vibration

*Incorrect belt tension-Adjust belt tension.

*Dry spindle quill-lubricate spindle quill.

*Spindle pulley loose-tighten retaining nut.

*Motor pulley loose-Tighten set screw.

*dull drill bit-resharpen drill bit.

Drill bit burns

*incorrect speed-reduce speed.

*Chips clogged-retract drill bit frequently

*dull drill bit-resharpen drill bit.

*feeding too slow-
feed faster.

Drill leads off

*cutting lips or angle not equal-
resharpen drill bit correctly.

*drilled hole off center-
drill a pilot hole first.

*bent drill bit-
use a proper drill bit.

*drill bit not properly installed-
install drill bit correctly.

10. Environmental protection

Protect the environment.

Your appliance contains valuable
materials which can be recovered or
recycled. Please leave it at a
specialized institution.



This symbol indicates separate
collection for electrical and electronic
equipment required under the WEEE
Directive (Directive 2012/19/EC) and is
effective only within the European
Union.

11. Available accessories

Refer to the PROMAC-Pricelist.